

OPERATION MANUAL

RI 2012

SRI Instruments Europe GmbH
Menzenberger Str. 93 · D – 53604 Bad Honnef, Germany
Telephone: +49 (0) 2224 766 15 · Telefax: +49 (0) 2224 988 09 43
<https://sri-instruments-europe.com>

Printed: 28.08.2014

File: *RI2012 V1.02 EN 08-2014.docx*
Last modified: Makowski

TABLE OF CONTENTS

TABLE OF CONTENTS	1
1 CONTACT ADDRESS	3
2 PRECAUTION AND WARNINGS	4
3 ELECTRICAL WARNINGS	4
4 GENERAL WARNINGS	5
5 SPECIFICATIONS	7
6 PHYSICAL SPECIFICATIONS	8
7 GUARANTEE CONDITIONS	9
8 PARTS INCLUDED IN THE DELIVERY	10
9 FRONT PANEL AND KEYBOARD	11
9.1 THE DISPLAY	11
9.2 THE AUTOZERO BUTTON	12
9.3 THE PURGE BUTTON	12
9.4 THE BUTTON POL +/-	12
9.5 THE BUTTONS ARROWLEFT (◀) AND ARROWRIGHT (▶)	12
9.6 THE BUTTONS ARROWUP (▲) AND ARROWDOWN (▼)	12
9.7 THE MENU BUTTON	12
9.8 THE ENTER BUTTON	13
9.9 THE IN PORT	13
9.10 THE OUT PORT	13
10 THE BACK SIDE OF THE RI2012	14
10.1 OUTPUT-CONNECTORS	14
10.1.1 THE INTEGRATOR SIGNAL OUTPUT	14
10.1.2 THE RECORDER SIGNAL OUTPUT	14
10.1.3 THE DIGITAL OUTPUT	14
10.2 INPUT-CONNECTORS	15
10.2.1 THE EXTERNAL START SIGNAL	15
10.2.2 THE EXTERNAL AUTOZERO SIGNAL	15
10.2.3 THE EXTERNAL PURGE SIGNAL	15
10.3 RS232 PORT	15
10.4 USB – 2.0 PORT	15
10.5 MASS SCREW	15
10.6 OPTICAL ADJUST	16
10.7 DRAIN	16
10.8 MAINS ADAPTOR	16
10.9 FUSES	16
11 INSTALLATION OF THE RI2012	17
11.1 CONNECTING THE DETECTOR TO THE CHROMATOGRAPHY SYSTEM	17
11.2 CONNECTION TO AN ANALOG DATA SYSTEM	18
11.3 CONNECTION TO A DIGITAL DATA SYSTEM (PC)	18

12 PRINCIPLE OF DETECTION	19
12.1 THE OPTICAL SYSTEM OF THE RI2012	19
13 Flow Paths in the RI2012	20
13.1 MEASURING MODE WITH ASCO VALVE	20
13.2 PURGE MODE WITH ASCO VALVE	21
14 OPERATING THE RI2012 DETECTOR	22
14.1 OVERVIEW FIRMWARE VERSION 5.2	22
14.2 THE INITIALIZATION STAGE	23
14.3 THE NORMAL MEASURING MODE (NORMMODE)	24
14.4 TEMPERATURE SETTINGS	26
14.5 SETTING SIGNAL SMOOTHING	28
14.6 SETTING RECORDER RANGE – SIGNAL AMPLIFICATION	29
14.7 SETTING RECORDER OFFSET AND RECORDER EXTENT	30
14.7.1 RECORDER OFFSET	30
14.7.2 RECORDER EXTENT	31
14.8 MARKERS	32
14.9 SETTINGS FOR SERIAL PORT (RS232)	33
14.10 MENU STRUCTURE IN NORMAL MEASURING MODE (NORMMODE)	34
15 THE SERVICE MODE	35
15.1 FIRMWARE INFORMATION	36
15.2 VIEWFINE MODE	37
15.3 ADJUSTING DIGITAL – ANALOG – CONVERTERS	39
15.4 CALIBRATING THE RI2012	40
15.4.1 HOW TO CALIBRATE...	41
15.5 SERVMODE OVERVIEW	44
15.6 SERIAL (RS232) COMMUNICATION	45
15.7 USB COMMUNICATION	46
16 MAINTENANCE OF THE RI2012	47
16.1 IDENTIFYING HARD- AND SOFTWARE	47
16.2 ERROR MESSAGES	48
16.2.1 MALFUNCTION OF THE TEMPERATURE SENSOR	48
16.2.2 MALFUNCTION OF THE ANALOG DIGITAL CONVERTER	49
16.2.3 ERROR MESSAGE “SIGNAL# TOO LOW” OR “SIGNAL# TOO LOW”	50
16.2.4 SIGNAL OUT OF RANGE	51
16.2.5 RESET CONFIGURATION	52
16.3 ADJUSTING THE OPTICAL SYSTEM	53
16.4 LAMP EXCHANGE AND ADJUSTMENT OF THE LAMP	55
16.5 CHECKING SUM- AND DIFFERENCE VOLTAGES	59
16.6 CHECK AND REPLACEMENT OF THE VALVE	62
16.7 CHECKING AND CLEANING THE FLOW CELL	63
16.8 THE HEATING CIRCUIT OF THE RI2012	65
17 VOLTAGE TEST POINTS	66
18 SPARE PARTS	68
DECLARATION OF CONFORMITY	69

1 CONTACT ADDRESS

In case of problems with your RI2012 refractive index detector please contact your local distributor or SRI Instruments Europe GmbH.

SRI Instruments Europe GmbH
Menzenberger Str. 93
D – 53604 Bad Honnef
Germany

Phone: +49 (0) 2224 766 15

Fax: +49 (0) 2224 988 09 43

<https://sri-instruments-europe.com>
mail: mailto@sri-instruments-europe.com



[GC](#) ▾ [HPLC](#) ▾ [Downloads](#) ▾ [Company](#) [Contact](#)

Call us: +49 (0)2224 766 15



Welcome

SRI Instruments Europe GmbH is a worldwide manufacturer and distributor of gas chromatographs, autosamplers, HPLC systems, software, columns and accessories.

Our scientific partners are institutes, universities and authorities as well as laboratories from the environmental – food – and biotech industry since 30 years.

Innovative electronics and a good reproducibility of the analysis results are our trademark. Our customers can expect tailor-made solutions and service-oriented action.

We are characterized by a high reliability – in case of problems we will not leave you alone.

Product Highlights



[GC Catalog](#)



[HPLC Catalog](#)

2 PRECAUTION AND WARNINGS

The manufacturer is not reliable for any damage, harm or financial loss caused directly or indirectly by the use of this instrument if the instrument is handled without the observation of this manual or handling with carelessness.

NOTE

Please read this manual carefully before working with the RI2012 refractive index detector. In case of any question please do not hesitate to contact your local distributor or SRI Instruments Europe GmbH directly.

3 ELECTRICAL WARNINGS

- Before opening the housing of the instrument make sure the detector is switched off and disconnected from power supply.
- The voltage selected at the fuse on the backside of the instrument has to be set correctly to 110 V or 220 V according to your local power supply.
- Before changing the selected voltage the power supply has to be disconnected.
- The detector may only be connected to plugs with grounding.
- The RI2012 may only be operated in connection with other devices which fit to the safety requirements.

4 GENERAL WARNINGS

- To prevent damages of the RI2012 all capillaries and cables have to be checked for damages and leakages.
- For the disposal of inflammable and/or toxic solvents a plan for waste management has to be created. Such solvents may not get into the drain.
- The RI2012 refractive index detector is built to operate at temperatures between 10 °C and 35 °C.
- To reach a reliable operation of the detector it is recommended to use filtered samples and solvents only.
- The detector may be cleaned with appropriate cleaning agents only.
- Make sure that no liquid gets inside the detector. Liquid inside the housing may cause electrical short circuits which may result in the damage of the instrument.
- To prevent electrical shocks make sure that the detector is disconnected from power supply when the housing is opened to perform service work inside.
- To disconnect the instrument from power supply simply unplug the power cable.
- Electronic circuit boards and electronic components are sensitive to electrostatic charges.
- For some maintenance operation it is required to open the instrument's housing. Make sure that the instrument is disconnected from power supply before removing the housing. If it is necessary to remove the housing during operation make sure not to touch electrical parts inside the detector.
- In case of the use of dangerous solvents pay attention to safety instructions regarding this solvent.

- Solvents should be degassed before use with a refractive index detector.
- After use of salt containing solvents (such as buffers) the detector should be purged with distilled water.
- Make sure that the 6 bar (0.6 MPa) pressure limit of the flow cell is not exceeded.
- Make sure that the 2 bar (0.2 MPa) pressure limit of the valve is not exceeded.
- During operation the housing of the detector should be closed.
- Do not use the detector in ambience of aggressive gases, very high humidity, strong vibrations and strong changes in the ambient temperature.

5 SPECIFICATIONS

Type of detection:	Refractive Index
Effective range for refractive index:	1.00 – 1.75 RIU
Effective range:	$\pm 1000 \mu\text{RIU}$
Optical null balance:	In the whole effective range by adjusting the mirror
Signal null balance:	In the whole effective range with AutoZero function
Solvent wetted materials	Stainless steel, glass, PTFE
Maximum pH-range:	2.3 – 9.5
Temperature control optical bench:	7°C above ambient temperature, 35 °C up to 55 °C in 1 °C steps
Analog signal output:	Recorder / integrator
Noise (analog signal):	$\pm 7 \text{ nRIU}$ ($\pm 7 \mu\text{V}$)
Noise (digital output):	$\pm 3 \text{ nRIU}$ ($\pm 3 \mu\text{V}$)
Drift:	$< 1 \mu\text{RIU/h}$ ($< 1\text{mV/h}$)
Integrator output:	$\pm 1.2 \text{ V}$ (fix)
Recorder output:	$\pm 1.2 \text{ V}$ (adjustable)
Recorder range:	8 steps selectable in the region from 1/8 to 16/1
Recorder offset:	Selectable: 0 mV, 10 mV, 100 mV
Signal range (recorder):	Selectable: 10 mV, 100 mV, 1000 mV
Recorder marker:	Marker function ON/OFF
Flow cell:	Glass cell (quartz) with two chambers
Flow cell Volume:	4 μl RI 2012M / micro 9 μl RI 2012A / analytically 13 μl RI 2012P / semi-preparative
Angle:	45 ° RI2012M / RI2012A 5° RI2012P
Max. Pressure:	6 bar (0.6 MPa)
Max. Flow rate:	0.1 – 3.0 mL/min
Valve:	3/2 path valve, 12 V
Max. Pressure:	2 bar (0.2 MPa)
Volumes from input to sample cell:	6 μl RI 2012M / micro 24 μl RI 2012A / analytically 88 μl RI 2012P / semi-preparative
Communication:	
Digital interface:	RS232, bidirectional, USB 2.0
Digital input:	TTL (Purge, AutoZero, Start/Marker)
Digital output:	TTL (Intensity alarm)

6 PHYSICAL SPECIFICATIONS

Dimensions: 300 mm * 175 mm * 440 mm (W * H * D)

Weight: 9,6 kg

Voltages: Mains adaptor with voltage selector
100 – 120 V
220 – 240 V

Frequency: 50 or 60 Hz

Power consumption: max. 50 W

Temperature range: 10 °C to 50 °C

7 GUARANTEE CONDITIONS

The term of guarantee depends on you local law. Beside this SRI Instruments Europe GmbH affords guarantee for at least 12 months beginning after purchase of the RI2012 refractive index detector.

All instruments are tested and certified by SRI Instruments Europe GmbH quality control. Only defects which result from faulty manufacture or material defects are covered by the guarantee. In case of a defect the original sales slip will be needed to make use of the guarantee. Repair works covered by the guarantee may only be performed by SRI Instruments Europe GmbH or licensed distributors.

The following cases are not covered by the guarantee:

- Improper use (e. g. capacity overload, use of not approved tools) of the RI2012 detector
- Parts which are liable to aging or abrasion like lamps, valves, heater cartridges or flow cells
- Damages caused by use of force or not approved tools
- Damages which result from improper use due to non-observance of the operation manual, the use under abnormal conditions or improper maintenance
- Defects resulting from the use of third-party parts which are not approved by SRI Instruments Europe GmbH
- Instruments which are modified after purchasing by the customer
- Normal abrasion
- Fully or partial disassembled refractive index detectors

8 PARTS INCLUDED IN THE DELIVERY

Quantity	Description
1 EA	Refractive Index Detector RI2012
1 EA	Stainless steel capillary, 0.25 mm inner diameter, 1.59 mm outer diameter (for sample entry)
1 EA	Stainless steel capillary, 1.00 mm inner diameter, 1.59 mm outer diameter (for sample exit)
1 EA	PTFE tube, 1.59 mm inner diameter, 2.80 mm outer diameter (for sample exit)
2 EA	Screw connection (for sample entry and sample exit)
1 EA	Power cable
2 EA	Fuses (0.5 A, slow)
2 m	Signal cable, 2-wired
1 EA	Hex-wrench (for adjustment of the mirror, \varnothing 2.5 mm)
1 EA	Operation & Service Manual

9 FRONT PANEL AND KEYBOARD

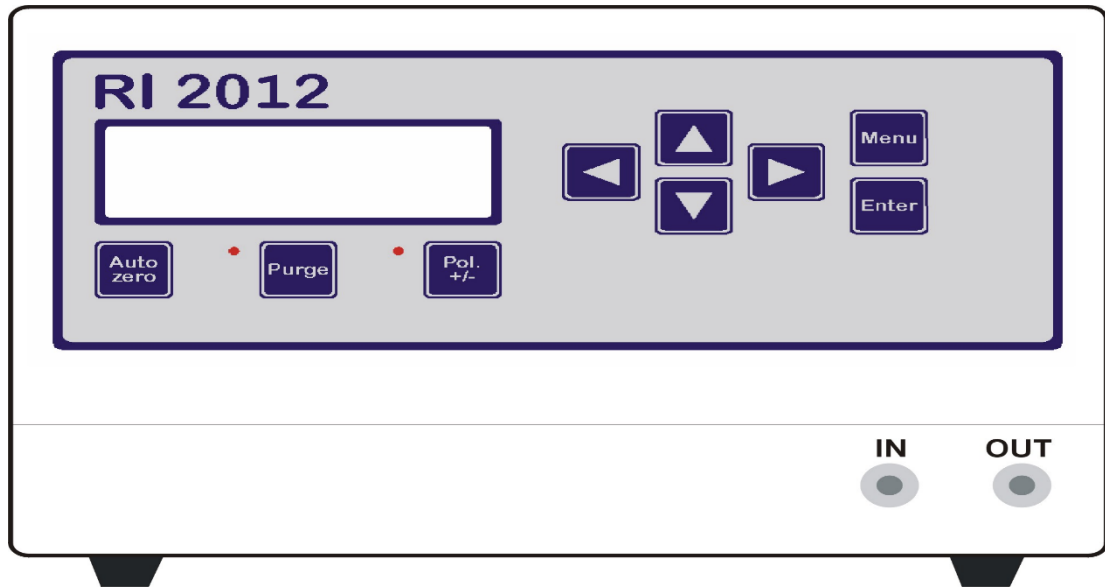

9.1 THE DISPLAY

The RI2012 refractive index detector is equipped with a liquid crystal display to show the current detector signal as well as system parameters. This display contains four lines with 20 characters each.

```

Temp : _____ 28.5 °C
OptBal : _____ 13.4 %%
SIGNAL : _____ 31.7 mV
NormMode OK Menu ,◇,↙
  
```

- Line 1 shows the current temperature of the optical bench (in °C).
- Line 2 shows the optical balance (in %%).
- Line 3 shows the current detector signal (in mV).
The value shown here is identical to the digital output signal and to the analog signal which can be recorded at the recorder output.
- Line 4 This line shows the status of the RI2012 detector. Every few seconds the displayed parameter changes. By this you can get a complete overview of all parameters in a short time.

9.2 THE AUTOZERO BUTTON

By pressing the **AutoZero** button the detector signal is internally set to Zero. To return to the former (unmodified) signal, press the **AutoZero** button for approx. three seconds.

9.3 THE PURGE BUTTON

To flush the reference chamber of the flow cell with mobile phase press the **PURGE** button once. If the purge mode is activated a red LED will light up. Press the **PURGE** button once again to deactivate the purge mode. Now the mobile phase will flow only through the sample chamber of the flow cell.

9.4 THE BUTTON POL +/-

By pressing this button the polarity of the detector signal will be changed. A negative signal like e. g. -5mV will be transformed into a positive signal $+5\text{mV}$ when the polarity mode is activated. A red LED will light up when this mode is activated.

9.5 THE BUTTONS ARROWLEFT (◀) AND ARROWRIGHT (▶)

These arrow buttons have several functions. If only one button is pressed you can change the settings of one parameter to smaller (◀) or bigger (▶) values. If both buttons are pressed together for about three seconds the detector will be set to the service mode.

9.6 THE BUTTONS ARROWUP (▲) AND ARROWDOWN (▼)

If different options for one parameter are available you can select the desired option by using these arrow buttons. **ArrowUp** (▲) will switch to higher values and **ArrowDown** (▼) to smaller values.

If the marker function is activated you can send a marker signal to the recorder output by pressing the **ArrowUp** (▲) button (see chapter 14.8).

9.7 THE MENU BUTTON

By pressing this button you can select a special sub menu or discard changes you performed on a parameter.

9.8 THE ENTER BUTTON

Press the **ENTER** button to open the selected sub menu and to accept changes you performed on a parameter.

9.9 THE IN PORT

This is the entrance for the mobile phase coming from the column. Connect the capillary coming from the column to this port using screw connectors.

9.10 THE OUT PORT

This is the exit of the mobile phase. Connect you waste bottle to this port using the PTFE tube.

NOTE

Use only capillaries with an inner diameter of 1 mm for the exit of the mobile phase. By this blockage can be prevented. Make also sure that the pressure limits for the flow cell (6 bar, 0.6 MPa) and the valve (2 bar, 0.2 MPa) are not exceeded.

10 THE BACK SIDE OF THE RI2012

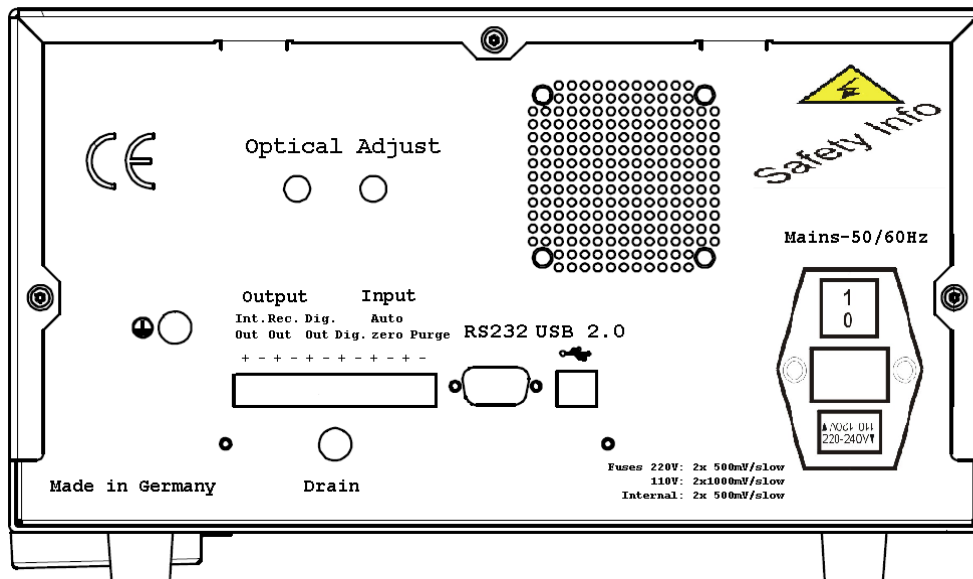

10.1 OUTPUT-CONNECTORS

The RI2012 refractive index detector has two analog and one digital signal output.

10.1.1 THE INTEGRATOR SIGNAL OUTPUT

If you want to record your data using an analog integrator device, connect the integrator using a shielded signal cable to the integrator output (Int. Out). Make sure that the polarity (+/-) is correct.

10.1.2 THE RECORDER SIGNAL OUTPUT

To record data using an analog recorder, connect the device using the shielded signal cable to the recorder output (Rec. Out). Make sure that the polarity (+/-) is correct.

10.1.3 THE DIGITAL OUTPUT

The RI2012 gives a TTL pulse in case of an intensity alarm. This pulse is given to the digital output (Dig. Out). If you want to record the digital detector signal you need to use the RS232 serial connector.

10.2 INPUT-CONNECTORS

The RI2012 refractive index detector has three digital (TTL) inputs. These can be used to control the system externally.

10.2.1 THE EXTERNAL START SIGNAL

Use the digital input connector (Dig.) to connect an external start signal (e. g. generated by an autosampler or a manual injector) to the instrument.

10.2.2 THE EXTERNAL AUTOZERO SIGNAL

Use this input connector (AutoZero) to connect an external AutoZero signal to the instrument.

10.2.3 THE EXTERNAL PURGE SIGNAL

Using this connector (Purge) you can use an external signal to activate the detector's purge mode.

NOTE

All TTL signals handled by the RI2012 detector use a TTL level which is based on instrument's ground potential.

10.3 RS232 PORT

The RS232 port can be used to acquire the detector's signal using a personal computer as well as to control the instrument using the computer. To communicate with the detector using a computer you need to use a certain protocol which is explained in [chapter 15.6](#) of this manual.

10.4 USB – 2.0 PORT

THE USB-2.0 PORT CAN BE USED TO ACQUIRE THE DETECTOR'S SIGNAL USING A PERSONAL COMPUTER AS WELL AS TO CONTROL THE INSTRUMENT USING THE COMPUTER. TO COMMUNICATE WITH THE DETECTOR USING A COMPUTER YOU NEED TO USE A CERTAIN PROTOCOL WHICH IS EXPLAINED IN [CHAPTER 15.7](#) OF THIS MANUAL.

10.5 MASS SCREW

Use the mass screw to connect the shielding of the analog signal cable to the detector's chassis. This will result in a smoother detector signal.

10.6 OPTICAL ADJUST

Remove the cover from RI2012. Inside the RI2012 you find the optical system in an extra housing. There are two holes at the backside of the optical system housing. In each hole is a screws to adjust the optical system. If needed the optical system can be adjusted using the hex-wrench which came with the instrument. Put the hex-wrench into one of the opened hole at the back side of optical system

■ NOTE

There are two adjustment screws for the mirror. Keep in mind that you might have to turn the other screw. Anyway you should turn the screws not more that 1/5 - 1/8 turns.

Adjust the screws until the optical balance reaches a value of $0 \pm 10 \%$. Now the adjustment for the used solvent is finished.

10.7 DRAIN

In case of a leakage inside the housing mobile phase can leave the housing using the tube. You might connect an additional waste tube to this exit.

10.8 MAINS ADAPTOR

Use the power cable which was delivered with the detector to connect the instrument to the power supply. Make sure that the correct voltage is selected before connecting to the mains. To high voltage will damage the instrument.

10.9 FUSES

Next to the mains plug you can find the instrument's fuses. The type of this fuse depends on the voltage the instrument is operated.

220 V:	2 x 500 mA, slow
110 V:	2 x 1000 mA, slow

Inside the housing is an additional internal fuse (1 x 500 mA, slow).

11 INSTALLATION OF THE RI2012

11.1 CONNECTING THE DETECTOR TO THE CHROMATOGRAPHY SYSTEM

Connect the INLET on the front of the detector to the capillary which comes from the column of your chromatography system. To attach the column to the detector use a 1/16" stainless steel capillary with 0.25 mm inner diameter.

Connect the 1/16" stainless steel capillary with 1 mm internal diameter to the PTFE tube and the OUTLET port of the instrument. Use the screw connections to fix the capillaries to the INLET and OUTLET port.

Place the free end of the PTFE tube in a bottle for solvent waste. The droplets leaving the tube should run along the bottles wall and not fall down. The waste bottle and the refractive index detector should be positioned at the same high level.

If you need a solvent mixture to perform your analytical separation it is recommended to mix the different components manually before using the solvent. The use of a gradient pump to generate a solvent mixture is not possible as the mixture generated by the gradient pump is not consistent. Small changes in the solvent compositions will result in unstable detector signals.

It is also recommended to degas the solvents before use with a refractive index detector as this will result in a more stable detector signal.

■ NOTE

Before dispatch of the instrument the flow cell was purged first with ethanol followed by air. However there are still some rests of ethanol in the flow cell. For transportation or long time storage of the instrument the procedure of purging with ethanol and air is recommended.

■ NOTE

The flow cell is built of specialized optical glass which is sensitive to pressure. The maximum pressure for the flow cell is **6 bar (0.6 MPa)**. If you want to use several detectors in series make sure that the refractive detector is the last one in the row to prevent damages of the flow cell due to high pressure.

11.2 CONNECTION TO AN ANALOG DATA SYSTEM

Use a small screwdriver to connect the signal cable to one of the two pin connectors which are delivered with your instrument. Connect the signal cable either to re integrator output (Int. Out) or to the recorder output (Rec. Out) of the detector if you want to use an analog integrator or recorder as well as an analog data system to collect data. Make sure that the polarity (+/-) of the connection is correct.

■ NOTE

The signal coming from the integrator output (Int. Out) is a voltage between -1 V and 1 V. In case of a signal gain of 1 set in the detector parameters the signal at the recorder output (Rec. Out) is the same.

If you need a very high sensitivity it is recommended to use the recorder output (Rec. Out) as you can use the instrument's internal signal amplifier which might amplify the detector signal up to 16 times.

11.3 CONNECTION TO A DIGITAL DATA SYSTEM (PC)

The RS232 port on the back side of the RI2012 refractive index detector can be used for data acquisition as well as instrument control. Using the RS232 port for external instrument control you might activate / deactivate the purge mode, send an external start / marker signal and AutoZero signal.

To communicate with the RI2012 detector using the serial interface you will need a special software package which utilizes a special communication protocol. Details of this protocol you will find in [chapter 15.6](#) of this manual.

There is a software package available which allows the data acquisition with the RI2012 detector. The data can be saved in user defined file formats for later data treatment using chromatography software packages like *PeakSimple* or *APEX*.

12 PRINCIPLE OF DETECTION

The RI2012 refractive index detector acts as a differential refractometer which measures the deflection of a light beam as a result of different refractive indices of solutions in the reference and the sample chamber of the flow cell.

The beam of a tungsten lamp passes a convex lens and two slit apertures (called slit 1 and slit 2) before reaching a second convex lens. After this the light passes the flow cell which is diagonally separated into two chambers (sample and reference chamber). Behind the flow cell a mirror is placed which reflects the beam through the flow cell, the second convex lens and the second slit aperture (slit 2) toward a light sensor.

The light sensor is placed under the light source and consists of two photo diodes. The both diodes generate a current which is proportional to the light intensity reaching the sensor's surface.

12.1 THE OPTICAL SYSTEM OF THE RI2012

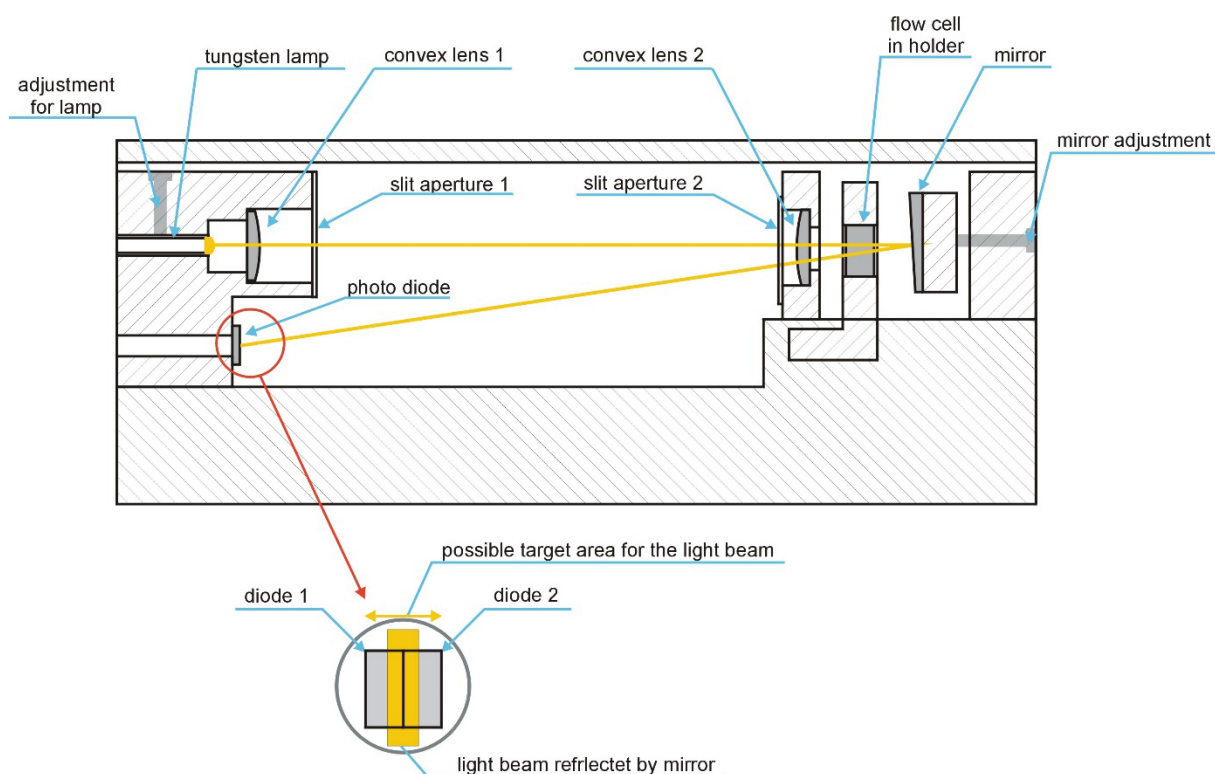

13 FLOW PATHS IN THE RI2012

13.1 MEASURING MODE WITH ASCO VALVE

If the purge mode is disabled (red LED is off) the valve is switched that way that the mobile phase does not pass the reference chamber of the flow cell. The mobile phase comes from the column and enters the optical system through the INLET port and a heat exchanger to ensure that the measurement is performed at constant temperatures as the refractive index is highly dependent on the temperature. The temperature for the optical bench can be selected in the range from 35 °C to 55 °C.

After passing the heat exchanger the mobile phase reaches the sample chamber of the flow cell. Leaving the flow cell the mobile phase flow again passes the heat exchanger going towards a T-connector which is connected with the purge valve. After passing the valve the liquid leaves the detector passing the OUTLET port.

The following figure illustrated the flow path in measuring mode with ASCO - Valve.

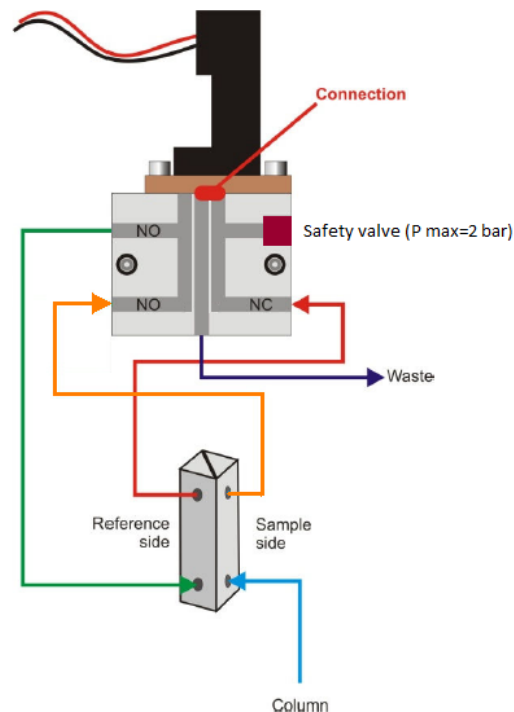

13.2 PURGE MODE WITH ASCO VALVE

The purge mode is used to flush the reference chamber of the flow cell with fresh mobile phase (solvent). If the purge mode is activated the red LED will light up. The mobile phase now passes the reference chamber of the flow cell.

After leaving the column the phase enters the detector passing the INLET port. After this the mobile phase enters the optical bench passing the heat exchanger going towards the flow cell. Now the stream enters the sample chamber of the flow cell. Leaving the flow cell, passing the heat exchanger again the liquid reaches the T-connector and after this it reaches the flow cell. Now the reference chamber is flushed by mobile phase. Leaving the flow cell the liquid is guided through the OUTLET port out of the detector.

The purge mode should be activated regularly to ensure that the reference chamber contains mobile phase (solvent) which is similar to the mobile phase passing the sample chamber.

After purging the detector for a certain time you can start your measurement after deactivation of the purge mode by pressing the **PURGE** button once again.

The following figure illustrates the liquid stream in purge mode with ASCO - valve.

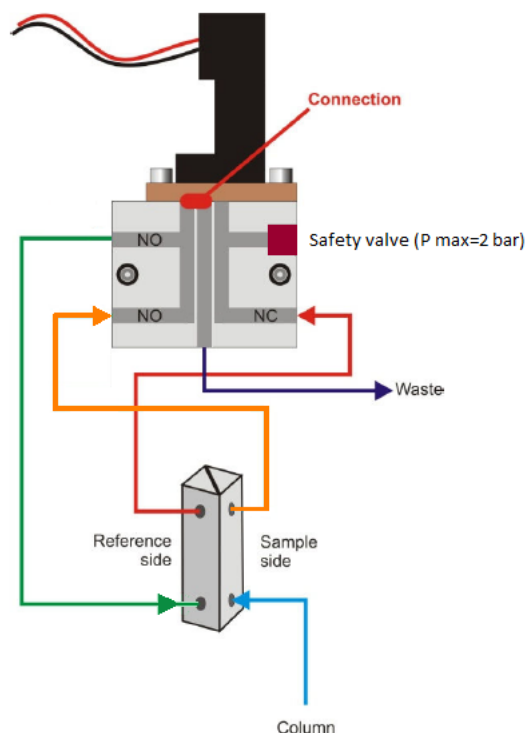

The purge mode should be activated until a stable baseline is reached. After switching back to the measuring mode it might be necessary to wait once more until the baseline becomes stable.

14 OPERATING THE RI2012 DETECTOR

14.1 OVERVIEW FIRMWARE VERSION 5.2

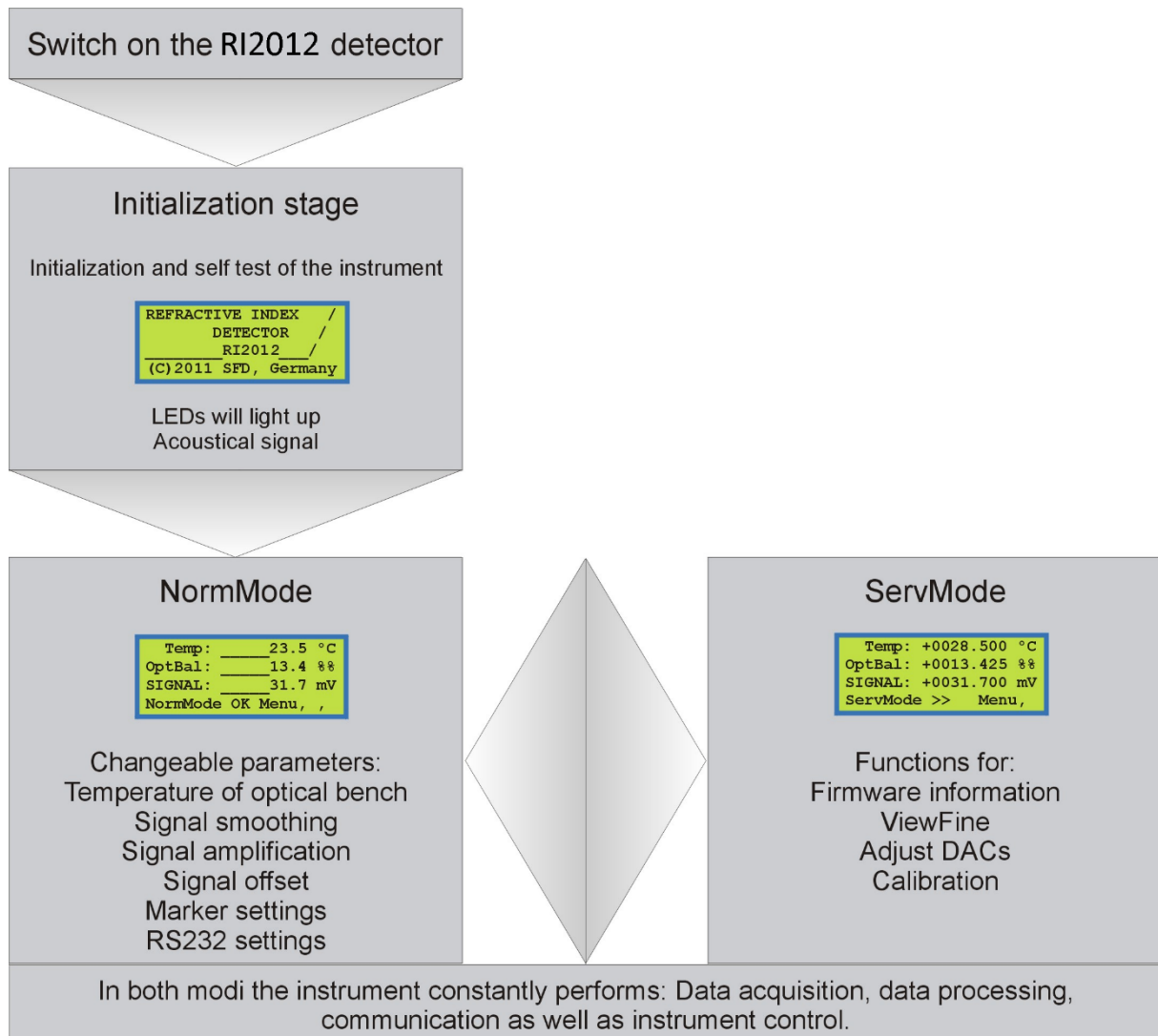

14.2 THE INITIALIZATION STAGE

The RI2012 refractive index detector does not consume any energy when it is switched off. The mains switch can be found on the back side of the instrument. After switching on the detector starts to initialize the internal micro controller and a testing procedure starts to check several system parameters. During this test the logo is shown in the display, the LEDs will light up for a short time and an acoustical signal will occur. The initialization procedure will be finished after approx. six seconds and the detector will switch automatically to the normal measuring mode (NormMode).

If you want to check the functionality of the internal keypad you can perform two different tests while the logo is shown:

1. Shortly press one of the buttons on the keypad. The detector will switch to normal measuring mode (NormMode) without waiting.
2. Press and hold one of the buttons. In this case the detector will not proceed to normal measuring mode. Instead of this it will show the logo until another button is pressed.

14.3 THE NORMAL MEASURING MODE (NORMMODE)

After performing the internal test procedure the detector will switch automatically to the normal measuring mode (NormMode). Now internally several tasks are running:

- Data acquisition
- Data processing
- Data output
- Internal instrument control

The display will show the following information:

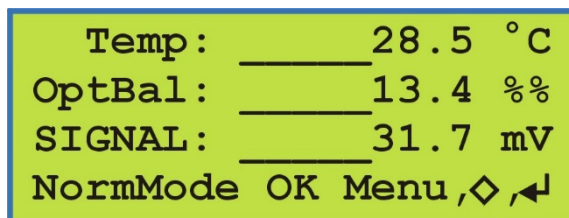

```
Temp : _____ 28.5 °C
OptBal : _____ 13.4 %%
SIGNAL : _____ 31.7 mV
NormMode OK Menu ,◇,↵
```

Line 1 shows the current temperature of the optical bench in [°C].

Line 2 shows the optical balance between the two photo diodes of the light sensor in [%%] which corresponds with the relative position of the light beam on the surface of the light sensor.

Line 3 shows the current detector signal or error messages (in case of intensity alarms). The shown signal corresponds with the signal which can be measured at the integrator output (IntOut). In the normal measuring mode (NormMode) the signal is displayed with one decimal.

Line 4 is the status line and shows the current status of different detector parameters. Several parameters are shown. Every few seconds the display will change that you will have a complete overview of all parameters in a short time.

The following parameters are shown:

- SetHeating, °C Temperature control
- SigSMOOTH Signal smoothing, internally
- RecRANGE Recorder output settings
- RecOFFSET, mV Signal offset for recorder output
- RecMARKER Marker settings
- ComRS232 Settings for serial RS232 port

Another function of the status line is the input of new parameter settings by the user. The symbol ❖ represents the four ARROW keys (◀▶▼▲), ↵ stands for the ENTER button.

Using the menu button you can choose between several sub-menus which are accessed when pressing the ENTER key after selection. To adjust the settings for the desired parameters use the ARROW buttons. To accept new settings press the ENTER button. To discard new settings and keep the old value press the MENU button.

14.4 TEMPERATURE SETTINGS

Since the refractive index is highly depending on the temperature the temperature of the optical bench of the RI2012 refractive index detector can be controlled by the micro controller. To set the desired temperature press the **MENU** button until the following status line is displayed.

```
Temp: _____ 28.5 °C
OptBal: _____ 13.4 %%
SIGNAL: _____ 31.7 mV
SetHeating, °C      OFF
```

Currently the temperature control is switched OFF. The optical bench is operated at ambient temperature plus additional 7 °C caused by internal heating resulting from different electronic components which heat up when operated. As a result of this the temperature can be controlled in a range from 35 °C up to 55 °C only. To change the temperature setpoint press the **ArrowUp** (▲) to switch to higher temperatures or use the **ArrowDown** button (▼) to select a lower temperature. If you set the temperature control to OFF the optical bench is operated at ambient temperature plus 7 °C.

Pressing the **ENTER** button accepts the new setting. In the normal measuring mode an asterisk (*) in the left top corner of the display indicates the activity of temperature control.

```
* Temp: _____ 35.0 °C
OptBal: _____ 13.4 %%
SIGNAL: _____ 31.7 mV
SetHeating, °C      +35
```

The temperature sensor is constantly controlled by the internal firmware of the instrument. It is not possible to activate the heating when one of the following reasons occurs:

- The temperature sensor does not work or is not connected. In this case the error message “noTS” will appear in the display.

- The current temperature is below 9 °C or above 64 °C. In this case the error message “!” will be shown in the display and a periodic acoustic signal occurs. The acoustic signal will stop when the temperature reaches the range between 9 °C and 64 °C.

■ NOTE

Should the temperature control fail due to an electronic malfunction the heating will be switched off automatically at 72 °C by a thermo fuse ([see chapter 16.8](#)).

14.5 SETTING SIGNAL SMOOTHING

To adjust the grade of smoothing of the detector signal press the menu button until the following status line is shown in the display.

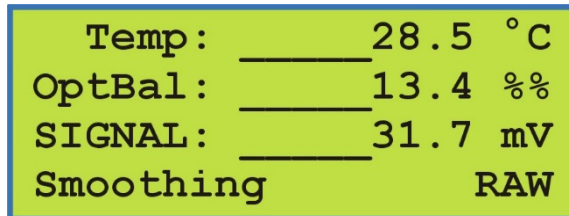

The image shows a digital display with a yellow background and a blue border. It displays the following information:

Temp :	_____	28.5 °C
OptBal :	_____	13.4 %%
SIGNAL :	_____	31.7 mV
Smoothing		RAW

There are four different modes for signal smoothing:

- **RAW** No signal smoothing
- **FAST** Signal smoothing by calculating the average in a time interval of 0.4 seconds
- **MEDIUM** Signal smoothing by calculating the average in a time interval of 0.8 seconds
- **SLOW** Signal smoothing by calculating the average on a time interval of 1.6 seconds

The **ArrowUp** button (**▲**) changes to the next faster way of signal smoothing while the **ArrowDown** button (**▼**) switches to the next slower mode. To accept the new settings press the **ENTER** button.

14.6 SETTING RECORDER RANGE – SIGNAL AMPLIFICATION

To adjust the signal amplification press the **MENU** button until you can see the following status line in the display.

Temp :	28.5	°C
OptBal :	13.4	%%
SIGNAL :	31.7	mV
RecRANGE	1/1	

If the mode RecRANGE is activated it allows to amplify or attenuate the detector signal at the recorder output (RecOut).

If the amplification mode is set to “1/1” the signal at the recorder output (Rec. Out) corresponds to the signal at the integrator output (Int. Out).

By pressing the buttons **ArrowUp** (▲) you can switch to the next stronger amplification mode of the signal:

$1/1$ ▲ $2/1$ ▲ $4/1$ ▲ $8/1$ ▲ $16/1$ ▲ $32/1$ ▲ $64/1$ ▲ $128/1$

Using the **ArrowDown** (▼) button you can change the amplification to lower grades:

$1/1$ ▼ $1/2$ ▼ $1/4$ ▼ $1/8$ ▼ $1/16$ ▼ $1/32$ ▼ $1/64$ ▼ $1/128$

To accept your settings press the **ENTER** button.

14.7 SETTING RECORDER OFFSET AND RECORDER EXTENT

In this sub menu you can adjust the recorder offset or the recorder extent. If the recorder adjust is activated a certain (defined) voltage will be added to each data point recorded by the detector. By setting the recorder extent you may define a maximum for the detector signal.

To adjust settings press the **MENU** button until the following status line is shown in the display.

Temp :	_____	28.5 °C
OptBal :	_____	13.4 %%
SIGNAL :	_____	31.7 mV
OutREC ,mV		0add

By pressing the buttons **ArrowUp** (▲) and **ArrowDown** (▼) you can either add a static voltage to each data point recorded by the detector (detector offset) or define a maximum voltage for the detector signal (detector extent).

14.7.1 RECORDER OFFSET

You can define a static voltage of 0 mV, 10 mV or 100 mV which is added automatically to the displayed detector signal. This is reasonable in the case of negative baseline drift in connection with a data system which cannot handle negative detector signals. To adjust the recorder offset press the buttons **ArrowUp** (▲) and **ArrowDown** (▼) until the desired voltage is shown in the status line of the display.

Temp :	_____	28.5 °C
OptBal :	_____	13.4 %%
SIGNAL :	_____	31.7 mV
OutREC ,mV		100add

0 mV ▲ 10 mV ▲ 100 mV or 100 mV ▼ 10 mV ▼ 0 mV

To accept the new setting, press the **ENTER** button. To leave the mode without accepting press the **MENU** button.

14.7.2 RECORDER EXTENT

To adjust the recorder extent press the **ArrowUp** button (▲) until the following status line is displayed.

Temp :	_____	28.5 °C
OptBal :	_____	13.4 %%
SIGNAL :	_____	31.7 mV
OutREC ,mV		10max

Using the **ArrowUp** button (▲) you can switch to higher maximum voltages, the **ArrowDown** (▼) button leads to smaller maximum voltages for the recorder output.

10max ▲ 100max ▲ 1000max ▲ EXTN (1250mV)

To accept the new settings press the **ENTER** button.

14.8 MARKERS

To modify settings concerning marker signals press the **MENU** button until the following status line is displayed:

Temp :	_____	28.5 °C
OptBal :	_____	13.4 %%
SIGNAL :	_____	31.7 mV
UseMarker		NONE

The function UseMarker can be used to send a marker signal to the recorder output. If the parameter UseMarker is set to NONE no marker signal can be sent to the recorder. Pressing one of the buttons **ArrowUp** (▲) or **ArrowDown** (▼) changes the setting to **ARROW↑**.

Temp :	_____	28.5 °C
OptBal :	_____	13.4 %%
SIGNAL :	_____	31.7 mV
UseMarker		ARROW↑

To accept this setting press the **ENTER** button. If this function is activated like this a marker signal can be sent to the recorder output each time the button **ArrowUp** (▲) is pressed. The height of the marker signal is set to $\pm 1/8$ of the selected recorder signal range. When the marker signal from the detector is sent, you will hear an acoustic signal.

14.9 SETTINGS FOR SERIAL PORT (RS232)

To modify settings concerning the digital communication using the serial RS232 port press the **MENU** button until the status line in the display changes to the following.

```

Temp: _____ 28.5 °C
OptBal: _____ 13.4 %%
SIGNAL: _____ 31.7 mV
ComRS232 _____ LOCK
  
```

Using this function ComRS232 you may adjust the parameters for the serial data interface. If the mode is set to “LOCK” no detector is sent to the RS232 port. Use this setting only in that case you want to record your data using an analog data system. Use the buttons **ArrowUp** (**▲**) and **ArrowDown** (**▼**) to select the frequency for data output. You can choose between two modes:

- 1 Hz One data point per second is sent to the RS232 port
- 10 Hz Ten data points per second are sent to the RS232 port

```

Temp: _____ 28.5 °C
OptBal: _____ 13.4 %%
SIGNAL: _____ 31.7 mV
ComRS232 _____ 1HZ
  
```

```

Temp: _____ 28.5 °C
OptBal: _____ 13.4 %%
SIGNAL: _____ 31.7 mV
ComRS232 _____ 10HZ
  
```

To accept you settings press the **ENTER** button. Pressing the **MENU** button will discard any new input.

14.10 MENU STRUCTURE IN NORMAL MEASURING MODE (NORMMODE)

Norm Mode

In this mode the user can adjust several parameters for the operation of the RI2012 refractive index detector.

The Norm Mode is used to:

- Display temperature [°C], optical balance [%%], and the current signal [mV].
- Modification and control of instruments settings.

In this mode the button **Menu** is used to switch between different sub - menus.

The button **Enter** is used to accept changes of parameters.

The arrow buttons **◀ ▶ ▲ ▼** are used to change between several possible options.

6 seconds after switching on the RI2012 refractive index detector the logo will disappear from the display and instruments switches to normal measuring mode

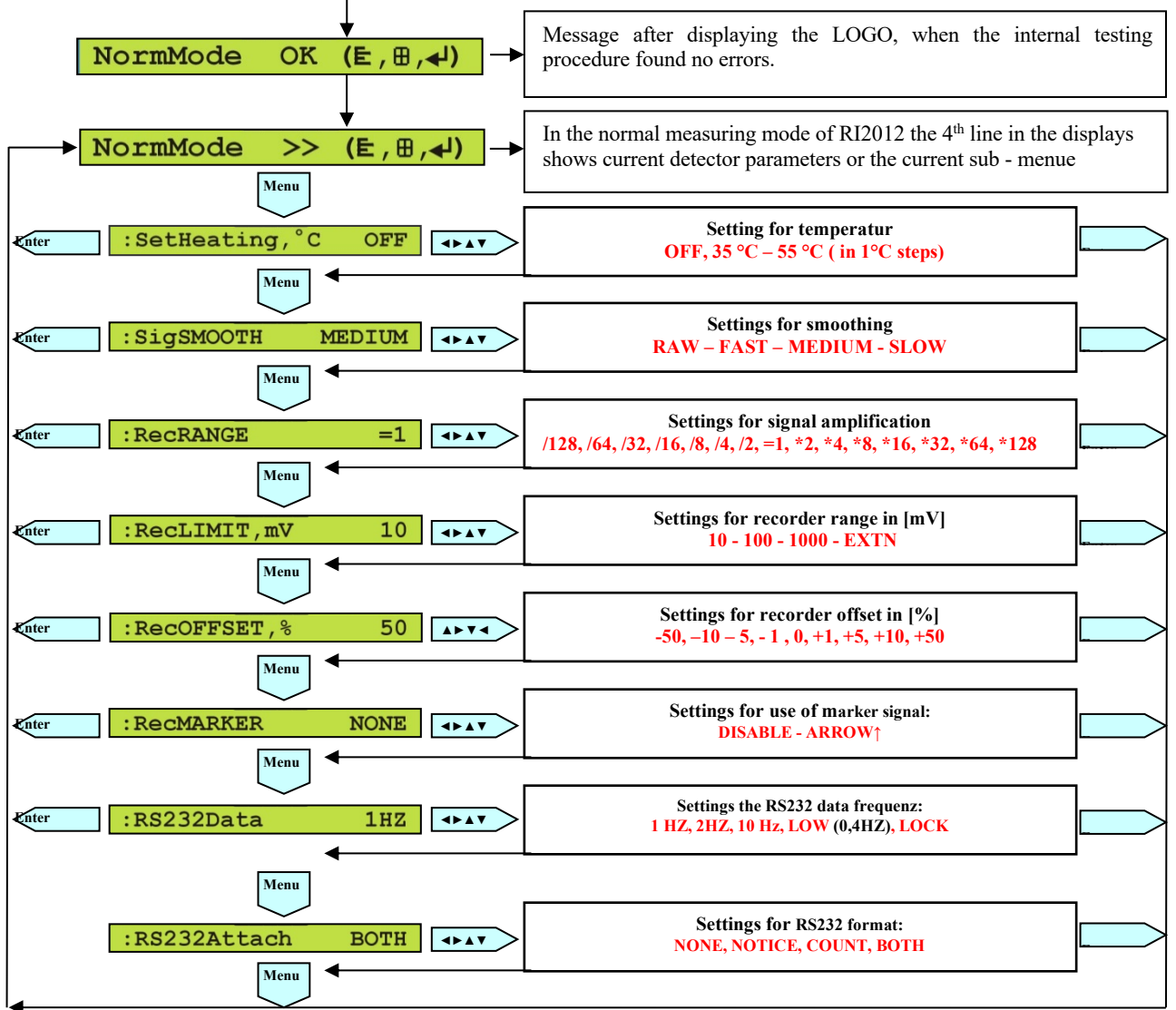

Caution: Use the Enter key here is to take over the set parameter

15 THE SERVICE MODE

Since version 3.x the internal firmware of the RI2012 refractive index detector contains the service mode. This mode allows the user to check more detailed system parameters for example in case of a malfunction of the instrument to get more detailed information to call the technical support.

To access service mode press the keys **ArrowLeft** (◀) and **ArrowRight** (▶) at the same time for about three seconds. The display will change from normal measuring mode (NormMode) to service mode (ServMode).

```
Temp: +0028.532 °C
OptBal: +0013.425 %%
SIGNAL: +0031.700 mV
ServMode >> Menu,↵
```

The numerical values for temperature, optical balance and the current detector signal are now displayed with three decimals. In this mode the status line is used to navigate between several sub menus.

You might choose between:

- NormMode switch back to normal measuring mode
- SwHwInfo switch to Software/Hardware information
- ViewFine switch to view fine system analysis mode
- AdjuDACs switch to adjust mode for digital analog converter
- Calibr'n switch to calibration mode

To switch back to the normal measuring mode press the **MENU** button until the NormMode statement is shown in the status line.

```
Temp: +0028.532 °C
OptBal: +0013.425 %%
SIGNAL: +0031.700 mV
ServMode >> NormMode
```

Now press the **ENTER** button to leave the service mode.

15.1 FIRMWARE INFORMATION

If you need detailed information about your instrument such as the firmware version number or the instrument's serial number press the **MENU** button in service mode until the menu SwHwInfo is shown in the status line.

```
Temp: +0028.532 °C
OptBal: +0013.425 %%
SIGNAL: +0031.700 mV
ServMode >> SwHwInfo
```

Then press the **ENTER** button. The display will show the currently running firmware version and the serial number of the instrument. The full information can be found in line two of the display.

```
S(c)hambeck SFD GmbH
RI2012 V5.2 0401G12
SIGNAL: -0031.700 mV
ServMode SwHwInfo
```

To return to the former display press the **MENU** button.

15.2 VIEWFINE MODE

To check internal settings of the refractive index detector the view fine mode can be activated. To access this mode press the **MENU** button until the sub menu ViewFine is shown in the status line.

```
Temp: +0028.532 °C
OptBal: +0013.425 %%
SIGNAL: +0031.700 mV
ServMode >> ViewFine
```

Now press the **ENTER** button and the display will change to the following information:

```
Check Source Unit ↵
-0010 5030 2510 2520
SIGNAL: +0031.700 mV
ServMode      ViewFine
```

The values in line two represent four different voltages measured by the instrument. To get an information which voltage is shown in which column press the **ENTER** button. The display will change to the following:

```
Check Source Unit ↵
  Diff Summ Smpl Rfrn
SIGNAL: +0031.700 mV
ServMode      ViewFine
```

To return to the former view press the **ENTER** button again.

The displayed shortcuts represent the following voltages:

- **Diff** Difference voltage. This is the difference between the voltages resulting from measuring light intensity on the sample and the reference side of the light sensor.
- **Summ** Sum-voltage. This is the sum of the two voltages measured on the sample and the reference part of the light sensor.
- **Smpl** Sample voltage. Corresponding to the light intensity on the sample side of the light sensor.
- **Rfrn** Reference voltage. Corresponding to the light intensity on the reference side of the light sensor.

All voltages are displayed in [mV]. The value of the difference voltage can be positive or negative while the values of the other three voltages have only positive values.

The sample voltage and the reference voltage can also be measured at two test points on the circuit board using a multimeter.

The sum and difference voltages are calculated according to the following formulas.

$$\mathbf{Summ} \quad = \quad \mathbf{Smpl + Rfrn}$$

$$\mathbf{Diff} \quad = \quad \mathbf{Smpl - Rfrn}$$

15.3 ADJUSTING DIGITAL – ANALOG – CONVERTERS

Press the **MENU** button until the sub menu “AdjuDACs” is shown in the display.

```
Temp: +0028.532 °C
OptBal: +0013.425 %%
SIGNAL: +0031.700 mV
ServMode >> AdjuDACs
```

Press the **ENTER** button to access the mode to adjust a digital to analog converter. The display will change to the following view:

```
Set both INT&REC on
fixValue: _____ mV ↵
SIGNAL: +0031.700 mV
ServMode      AdjuDACs
```

This function allows the user to apply a defined signal to the recorder output and the integrator output.

■ **NOTE**

Make sure that the signal amplification for the recorder output is set to 1/1 before using this function. Otherwise you have to remember the amplification factor.

This voltage can be checked using a multimeter or may be used to test the used data system. By pressing the **ENTER** button you can go stepwise through a list of different voltages.

0 mV ↵ 1000 mV ↵ 1200 mV ↵ 0 mV ↵ -1000 mV ↵ -1200 mV

Pressing the **ENTER** button once will show the following information in the display:

```
Set both INT&REC on  
fixValue: 0000 mV ←  
SIGNAL: +0031.700 mV  
ServMode AdjuDACs
```

Now the signal at the integrator output and the recorder output is exactly 0 mV. Press the **ENTER** button again to switch to the next voltage. The current voltage which is applied to the signal output is shown in the display.

15.4 CALIBRATING THE RI2012

The calibration mode of the RI2012 detector is used to calibrate the signal response to a certain sample concentration. This step is needed if the instrument is used to perform quantitative analysis. The detector is calibrated when shipped to the customer. Usually a re-calibration has to be performed after modifications of the optical system only. Under normal operation conditions a re-calibration of the RI2012 is not needed.

To calibrate the signal response of the instrument you need a solution of exactly **106 mg glucose in 100 mL distilled water** which is used as test solution. The refractive index of this solution is known and saved as an internal constant in the detectors firmware. The first step of the calibration is purging the reference chamber and the sample chamber of the flow cell with distilled water. In the second step the sample chamber is filled with the standard solution. At this point the theoretical detector signal is 500 mV. The real detector signal is recognized by the firmware and the calibration factor to reach the theoretical 500 mV is calculated and saved as internal constant.

The correlation between the refractive index and the detector signal is:

$$1 \text{ mV} = 1 \text{ } \mu\text{RIU}$$

15.4.1 HOW TO CALIBRATE...

To activate the calibration mode press the **MENU** button until the statement "Calibr'n" is shown in the status line.

```
Temp: +0028.532 °C
OptBal: +0013.425 %%
SIGNAL: +0031.700 mV
ServMode >> Calibr'n
```

By pressing the **ENTER** button the calibration mode is opened. The following information will be shown in the display. DifW = Difference with water, SumW = Summ with water, Dift = Difference with test solution, SumW = Summ with test solution,

```
← Current SPAN & its
  DifW SumW Dift SumT
SIGNAL: +0003.952 mV
ServMode Calibr'n
```

By pressing the **ENTER** button you can see the current SPAN.

```
← Current SPAN 05230
  0003 5009 0503 5003
SIGNAL: +0003.952 mV
ServMode Calibr'n
```

To start the calibration press the **ENTER** button. The following information will be shown in the display.

```
3-steps-Calibration:
yourTest toGet 500mV
SIGNAL: +0031.700 mV
ServMode AdjuDACs
```

To start the first step of calibration press the **ENTER** button. For the first step of calibration the valve will be switched automatically into purge mode (the red purge **LED** will light up). The display will show the line "nowWATERwash".

```
Step 1/3 PurgeWater
nowWATERwash, then ↵
SIGNAL: +0031.700 mV
ServMode   Calibr'n
```

At this point flush the reference chamber and the sample chamber with at least 5 mL distilled water. It is recommended to use a disposable syringe during the calibration to press the solutions into the INLET port. When the first step is finished, press the **ENTER** button. The display will change to the following view:

```
Step 1/3 PurgeWater
-0010 5030 ...WAIT !
SIGNAL: +0033.952 mV
ServMode   Calibr'n
```

The signal is recorded and checked. In the display line two the difference voltage (Diff, -0100 in this example) and the sum voltage (Summ, 5030 in this example) is shown.

If the signal is stable the display view will change to:

```
Step 2/3 InjectTest
nowTESTinto, then ↵
SIGNAL: +0471.935 mV
ServMode   Calibr'n
```

The valve is switched automatically into the measuring position. Now flush the sample chamber of the flow cell at least three times with the standard solution before pressing the **ENTER** button to proceed with step two of the calibration process. After pressing the **ENTER** button the detector registers the current signal while the display will show the different voltages as described before.

```
Step 2/3 InjectTest
0890 5060 ...WAIT !
SIGNAL: +0471.935 mV
ServMode Calibr'n
```

If the signal is stable the calibration factor is calculated and saved. The success of the calibration process is confirmed by a displayed message.

```
Step 3/3 SaveSession
Calibration was OK ↵
SIGNAL: +0492.980 mV
ServMode Calibr'n
```

Press the **ENTER** button to finish the calibration process. The new calibration factor is shown in the upper right corner of the display. The four measured and calculated voltages are shown in the display according to the ViewFine mode (see chapter 15.2). The calibration is now finished.

```
set new SPAN 02803
-0010 5030 0890 5060
SIGNAL: +0492.980 mV
ServMode Calibr'n
```

In case of a problem during the calibration, an error message will be displayed.

```
Step 3/3 SaveSession
Calibration failed
SIGNAL: +0492.980 mV
ServMode Calibr'n
```

In this case the RI2012 uses the old calibration factor for further measurements. Repeat the process of calibration as describe before.

15.5 ServMode Overview

This mode allows the user to get detailed information about the current status of RI2012.

If the calibration mode is not entered no changes can be applied on the instrument.

Features on service mode:

- More detailed display (3 decimal places) of temperature (°C), optical balance (%%) and detector signal (mV)
- System information (such as firmware version and serial number of the instrument)
- Display of optical bench parameters (reference/sample/sum and difference voltages)
- 3 – step - calibration of the detector response

In the service mode only the button **Menu** and **Enter** are active to select the different sub – menus and to accept new settings.

To discard changes and to leave a sub – menus press the **Menu** button.

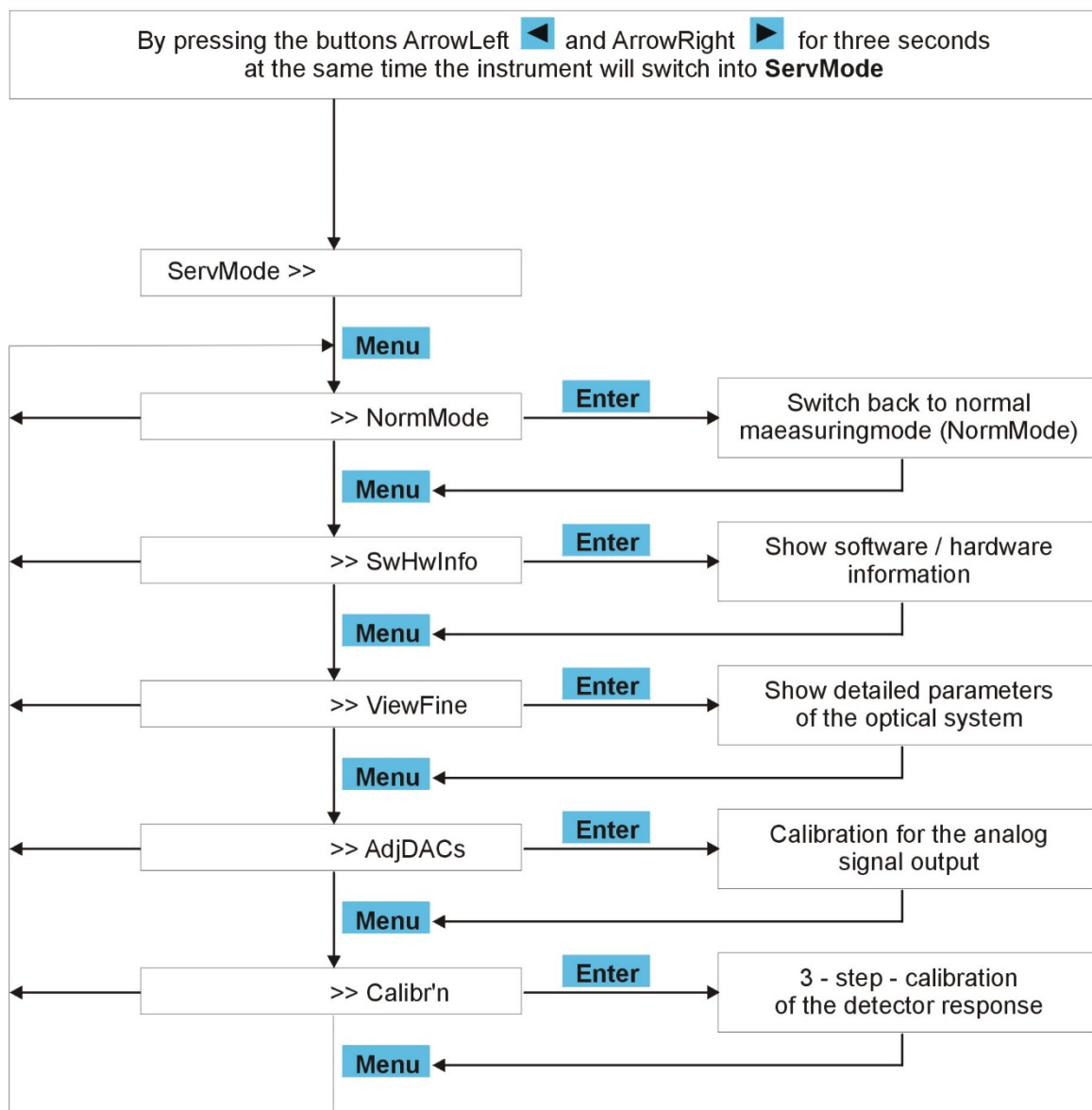

15.6 Serial (RS232) Communication

Refractive Index detector RI2012 – Serial RS232 Interface – Firmware V 5.02

The RS232 port is used for the communication of detector and computer.

The following option can be used to acquire data and control RI2012 refractive index detector.

- a) Clarity data acquisition software and instrument control from DATAAPEX.
- b) Special designed software solutions depending on the customer’s need
- c) Simple software solutions like Windows HyperTerminal or Putty or special macros for Microsoft Excel

Com RS232 settings (user settings on RI2012):

- LOCK serial port blocked in both directions
- LOW 0,4 Hz serial port open, 0,4 data point/sec sent
- 1 Hz serial port open, 1 data point / second sent
- 2 Hz serial port open, 2 data point / second sent
- 5 Hz serial port open, 5 data point / second sent
- 10 Hz serial port open, 10 data point / second sent

REMARKS:

- No start of data output at this point (more see below)
- Each time the ENTER key is pressed will stop data output
- Active data output is represented by three dots (...) in the line ComRS232

Communication: Computer is sending command, detector is sending data:

ASCII		Hex		
s	S	0x73	0x53	Start data output
h	H	0x68	0x48	Stop data output
z	Z	0x7A	0x5A	Set AutoZero flag
p	P	0x70	0x50	Set flag for

REMARKS:

- Setting a flag is not directly the operation
- Unused letter might be used in further versions

Data sent by RI2012

- Character 1: Space (0x20) acts as separator
- Character 2: Algebraic sign (+/-) (0x2D/0x2B)
- Character 3-9: 7 numbers, representing the voltage
- Character 10: Carrier Return (CR, 0x0D)
- Character 11: Line Feed (LF, 0x0A)

Message sent by RI2012

- GO (data output after external start signal)

Format: CR (0x0D), LF (0x0A), G (0x47), O (0x4F), CR (0x0D), LF (0x0A)

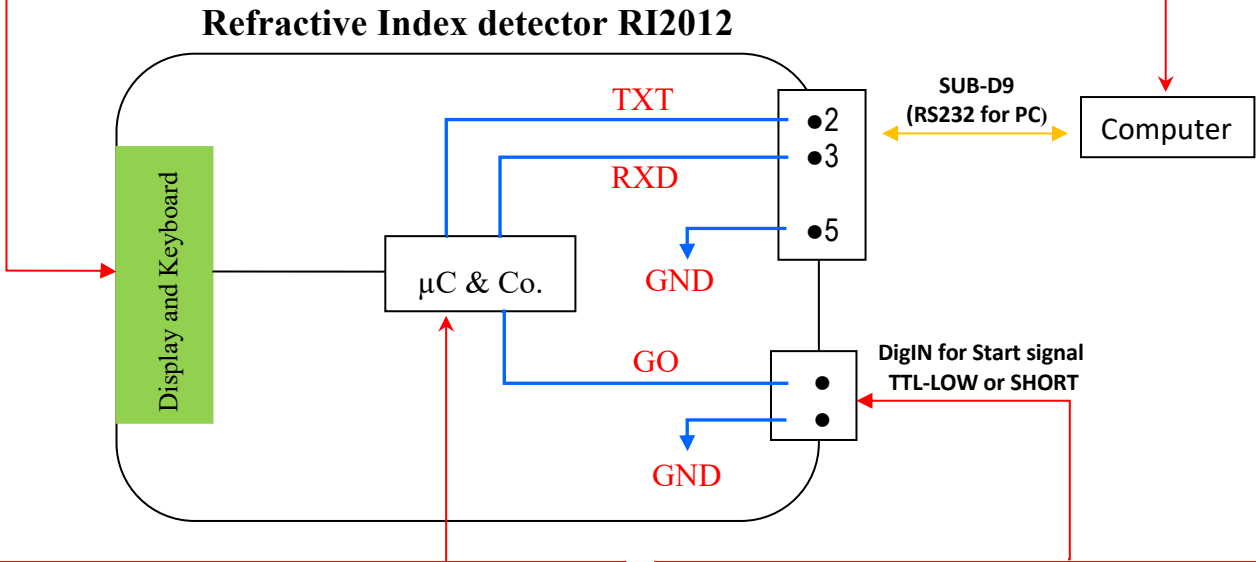

Specification of the RS232 port:

- - signal TXD (Pin #2) RDX (Pin #3) and GND (PIN #5)
- - baudrate: 9600, 8 data bits, no parity, 1 start bit, 1 stop bit
- - handshake: none
- - code: ASCII

External start - signal

One of the digital input (Dig In.) is used to start data output. The low edge results in the output of the text GO

15.7 USB Communication

USB -support

The RI2012 - Interface supports USB 2.0 High speed. To use the RI2012 with USB you have to install a Silicon Labs driver.

System Requirements

Silicon Labs 8-bit microcontroller software requires one of the following operating systems:

- Windows XP / Server 2003 / Windows Vista / Windows 7 and Windows 8 (v6.6.1)
- 500 MB Hard Disk Space

1) Download driver

for RI2012 USB Interface for Windows XP / Server 2003 / Windows Vista / Windows 7 and Windows 8 (v6.6.1)

Hyperlink for Drivers Windows and Mac: [CP210x VCP Drivers](#)

Or download from Silicon Lab website:

<http://www.silabs.com/products/mcu/Pages/USBtoUARTBridgeVCPDrivers.aspx>

2) Disconnect the RI2012 from Computer

3) Install the CP210x VCP Drivers for RI2012 - USB interface.

Follow the installation instructions on the screen.

4) Reboot Computer

5) Connect RI2012 with A/B-USB cable (USB printer cable) to PC-USB port.

The driver installation will performed automatically.

6) Select the correct COM Port NO.

You can see the COM Port NO. on the bottom right of the screen.

The COM Port NO. is also listed under in device manager "Silicon Bridge".

7) Connect the RI2012 to the Computer

It is also possible to add more than one RI2012 to the Computer. Another RI2012 device is automatically detected and installed. The new RI2012 unit get an own COM port number.

8) Communication tests

for Windows 7 - 32 and 64-bit system were successfully carried out.

Information: Older operation systems e.g. Windows 2000 require a different VCP driver (Virtual Com Port). You can download the different VCP "CP2102" driver from Silicon Labs. website <http://www.silabs.com>.

16 MAINTENANCE OF THE RI2012

16.1 IDENTIFYING HARD- AND SOFTWARE

If you need detailed information about your instrument such as the firmware version number or the instrument's serial number you can get this information in the service mode of the detector. Press the buttons **ArrowLeft** (◀) and **ArrowRight** (▶) at the same time for approx. three seconds. The display will switch into service mode.

```
Temp: +0028.532 °C
OptBal: +0013.425 %%
SIGNAL: +0031.700 mV
ServMode >> Menu,↵
```

Press the **MENU** button until the menu SwHwInfo is shown in the status line.

```
Temp: +0028.532 °C
OptBal: +0013.425 %%
SIGNAL: +0031.700 mV
ServMode >> SwHwInfo
```

Then press the **ENTER** button. The display will show the currently running firmware version and the serial number of the instrument. The full information can be found in line two of the display.

```
S(c) hambeck SFD GmbH
RI2012 V5.2 0401G12
SIGNAL: -0031.700 mV
ServMode SwHwInfo
```

To return to the former display press the **MENU** button. To exit the service mode select the menu NormMode by pressing the **MENU** button and press **ENTER**.

16.2 ERROR MESSAGES

In case of some malfunction the RI2012 refractive index detector may display an error message. The most error will appear directly after switching on the instrument.

16.2.1 MALFUNCTION OF THE TEMPERATURE SENSOR

There are two possible error messages indicating problems with the temperature sensor. A more detailed description of the temperature control of the RI2012 can be found in [chapter 16.8](#).

The message “noTS” (no temperature sensor) will appear for that reason that the temperature sensor is not connected to the circuit board or not working.

```
Temp:      _____ noTS °C
OptBal:    _____ 13.4 %%
SIGNAL:    _____ 31.7 mV
NormMode >> Menu, ⬠, ⬅
```

The message “!” is shown if the temperature of the optical bench is outside the range between 9 °C and 64 °C. Beside the displayed message an acoustic signal will occur.

```
! Temp:    _____ 8.2 °C
OptBal:    _____ 13.4 %%
SIGNAL:    _____ 31.7 mV
NormMode >> Menu, ⬠, ⬅
```

16.2.2 MALFUNCTION OF THE ANALOG DIGITAL CONVERTER

This error messages only occur directly after switching on the RI2012 refractive index detector.

```
Temp : _____ 28.5 °C
OptBal : _____ noAD %%
SIGNAL : _____ 31.7 mV
NormMode >> Menu, ⬆, ⬅
```

If this message “noAD” shows up the analog digital converter did not connect to the micro controller. Switch of the instrument, wait for ten seconds and try to start again. If the problem remains contact the technical support.

```
Temp : _____ noTS °C
OptBal : _____ noAD %%
SIGNAL : _____ mV
ServMode >> NormMode
```

After switching to service mode you will also notice the error message “noTS”. As the micro controller also controls the temperature of the optical bench this error message shows up but does not mean that there is a problem with the temperature sensor.

16.2.3 ERROR MESSAGE “**SIGNAL# TOO LOW**” OR “**SIGNAL# TOO LOW**”

The intensity alarm message can show up directly after initialization of the instrument or during operation. There are two different ways of displaying this message.

```
Temp: _____ 28.5 °C
OptBal: _____ 13.4 %%
SIGNAL: _too low! mV
NormMode >> Menu, ⬠, ⬅
```

```
Temp: _____ 28.5 °C
OptBal: _____ 13.4 %%
SIGNAL: _too high mV
NormMode >> Menu, ⬠, ⬅
```

It is normal that you get no beep from the RI2012 refractive index detector when you press the [AutoZero](#) or [PURGE](#) button while the “**SIGNAL# TOO LOW**” or “**SIGNAL# TOO LOW**” message is shown. In this case it makes no sense to press the [AutoZero](#) or [Polarity](#) buttons when there is no signal value shown in the display. The functions [AutoZero](#) and [Polarity](#) are only active if there is a detector signal.

Is the message “**SIGNAL# too low**” displayed, the voltage U_{Summ} is below 1.7 V. The reason is low light intensity reaching the light sensor.

To resolve this problem, try the following: Purge the reference chamber and the sample chamber of the flow cell and make sure that both chambers are filled with mobile phase

- Check the light source (see [chapter 16.4](#))
- Make sure the flow cell is clean (see [chapter 16.7](#))
- Adjust the alignment of the optical system (see [chapter 16.3](#))
- Check the lamp current, it might be too low. (see [chapter 16.4](#) and [page 58](#))

In case of the message “**SIGNAL# too high**” the problem is that the voltage U_{Summ} is beyond 7.5 V. This might be caused by several facts:

- The lamp current is too high, check lamp current
- The cover of the optical system is open and light from outside reaches the light sensor

16.2.4 SIGNAL OUT OF RANGE

The error message of the type “OVER_ADxx” shows up if the analog digital converter gets a signal which is too high or too low.

```
Temp: _____ 28.5 °C
OptBal: _____ 13.4 %%
SIGNAL: OVER_AD1H mV
NormMode >> Menu, ⬠, ⬅
```

```
Temp: _____ 28.5 °C
OptBal: _____ 13.4 %%
SIGNAL: OVER_AD1L mV
NormMode >> Menu, ⬠, ⬅
```

```
Temp: _____ 28.5 °C
OptBal: _____ 13.4 %%
SIGNAL: OVER_AD2H mV
NormMode >> Menu, ⬠, ⬅
```

```
Temp: _____ 28.5 °C
OptBal: _____ 13.4 %%
SIGNAL: OVER_AD2L mV
NormMode >> Menu, ⬠, ⬅
```

To localize the problem the “xx” in the error message is filled with a two letter code according to the following table

xx=1H	sample voltage beyond 5 V
xx=2H	reference voltage beyond 5 V
xx=1L	sample voltage below 0 V
xx=2L	reference voltage below 0 V

The sample voltage corresponds to the light intensity reaching the light sensor on the sample side, as the reference voltage corresponds to the light intensity reaching the light sensor on the reference side.

When this error message shows up, try the following to solve the problem:

- Purge the flow cell to ensure that both chambers are filled with mobile phase (without bubbles)
- Check the optical balance ([see chapter 16.3](#))

16.2.5 RESET CONFIGURATION

This type of error might only occur when the instrument is switched on. If the error message “RC” is shown in the display the controller was not able to load the internal configuration during the initialization.

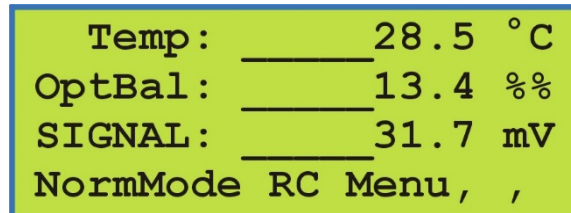

The image shows a digital display with a yellow background and black text. The text is arranged in four lines, each representing a different measurement or status. The first line shows 'Temp: 28.5 °C', the second 'OptBal: 13.4 %%', the third 'SIGNAL: 31.7 mV', and the fourth 'NormMode RC Menu, ,'. The 'RC' in the fourth line indicates a reset configuration error.

Temp:	28.5	°C
OptBal:	13.4	%%
SIGNAL:	31.7	mV
NormMode	RC	Menu, ,

In this case for example the calibration factor is not loaded. The instrument's setting will be set automatically to factory default settings. If you are performing quantitative analysis you have to re-calibrate your detector before you can proceed.

16.3 ADJUSTING THE OPTICAL SYSTEM

By adjusting the optical system of the RI2012 refractive index detector it is possible to influence the light intensity reaching the two photodiodes of the light sensor.

To perform the adjustment the sample chamber and the reference chamber of the flow cell have to be purged with distilled water. When both chambers contain the same liquid theoretically the same light intensity should reach the sample side and reference side of the light sensor. In this case the optical balance should be zero.

The adjustment of the optical system is performed manually. During this procedure the position of the light beam on the photo sensor is changed by adjusting the mirror.

During the procedure you can follow the changes by observing the change of the detector signal or more detailed by observing the difference and sum voltage.

For the calculation of the different voltages, the detector signal and the optical balance the following formulas are used:

$$Diff = S_{mpl} - R_{frn}$$

$$Summ = S_{mpl} + R_{frn}$$

$$OB = \frac{Diff}{Summ} \cdot 1000(\text{‰})$$

$$Signal = POL \cdot (OB \cdot C_0 - AZ)$$

Where Signal is the calculated detector signal, POL the selected polarity, C_0 is the calibration factor resulting from the 3-step-calibration and AZ the 'real' signal before pressing the AutoZero button.

The pre-set calibration factor is 2724. This factor is used if no 3-step-calibration of the instrument was performed.

To adjust the optical system follow the steps listed below.

- Switch to purge mode, make sure the red purge LED is on.
- Flush both chambers of the flow cell with clean mobile phase for several minutes.
- Switch back to measuring mode, make sure the red purge LED is off.
- Remove the cover from RI2012
- The optical system is in the extra housing.

- Put the hex-wrench into one of the opened hole at the back side of optical system.

■ NOTE

There are two adjustment screws for the mirror. Keep in mind that you might have to turn the other screw. Anyway you should turn the screws not more that 1/5 - 1/8 turns.

- Adjust the screws until the optical balance reaches a value of $0 \pm 10 \%$.

Now the adjustment for the used solvent is finished.

16.4 LAMP EXCHANGE AND ADJUSTMENT OF THE LAMP

It might be possible that you need to re-adjust the light source due to some changes in the used light bulb due to the transport or you need to replace a burned out lamp.

The adjustment of the light source is only possible when the housing is opened. To prepare for adjustment do the following steps:

- Switch off the instrument
- Unplug the mains cable to prevent electrical shock when opening the housing

■ **NOTE**

Some operations during the adjustment have to be done when the instrument is in operation. So you need to re-connect the mains cable and to switch on the RI2012 refractive index detector. When the instrument is operated with opened housing make sure that you do NOT touch any electrical component!



- Open the outer housing of the optical bench (chrome coloured)
- Open the inner black housing of the optical bench. You will see the optical system of the RI2012 refractive index detector. The components are shown below:

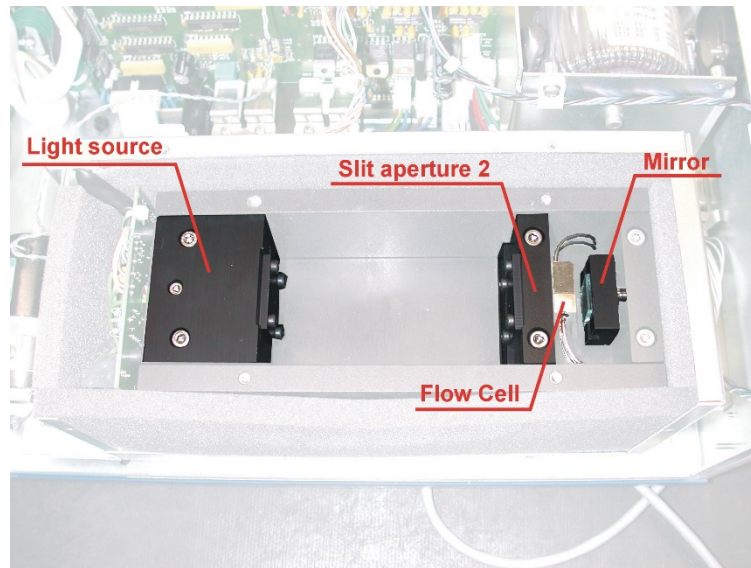

- Loosen the holding screw of the light source and remove the lamp.

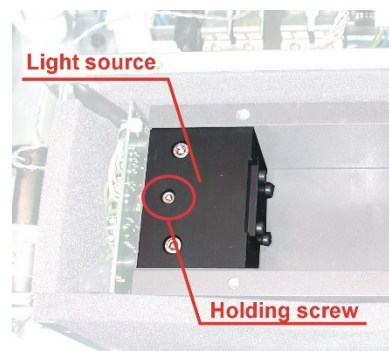

- Loosen the screw connector of the lamp's power supply at the pre-amplifier board (labelled: LAMPE)

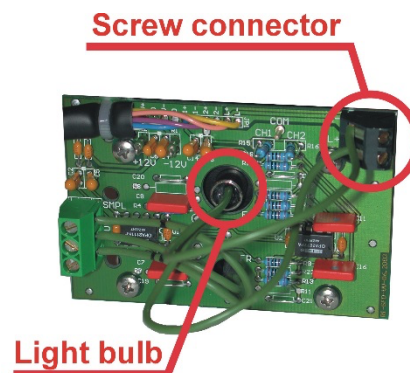

- Place a new lamp in the holder and tighten the holding screw

- Connect the power wires of the lamp with the screw connector on the pre-amplifier board.
- Connect the mains cable to the detector and switch on the instrument

■ NOTE

The following steps need to be performed on the running instrument. There is the danger of electrical shock when touching electrical components.

- Check Lamp Voltage. Use a voltmeter to check the lamp voltage at the test points on the circuit board. The label of this test point points are **Lampe ULmp** and **'GND'**.

The lamp voltage should be 3.7 ± 0.5 V.

If needed you can adjust this voltage by turning the **potentiometer R19** at the main circuit board.

In the following two steps the light bulb is positioned for optimal operation.

Step 1:

Place the lamp in the holder resulting in a sharp picture of the illuminated area at the slit aperture 2. Usually the metal cover of the light bulb ends with the holder, sometimes the metal cover stands about 1 or 2 mm out of the metal block.

Step 2:

Turn the light bulb that the picture of the filament is parallel to the slit of the second slit aperture.

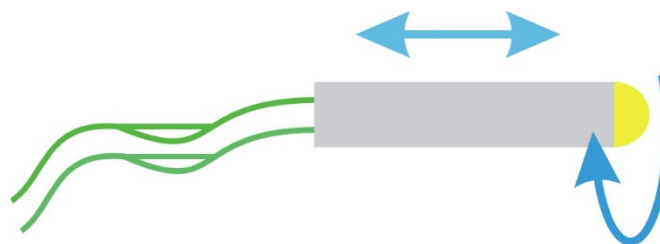

Make sure that only 2/3 of the slit are illuminated by the light source. This is illustrated in the following figure.

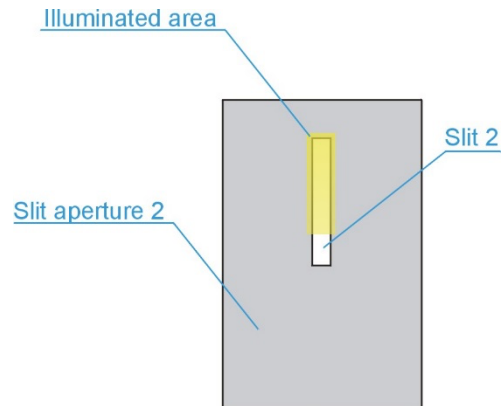

NOTE

The projected picture at the light sensor should be a sharp one. The full height of the photo diodes has to be illuminated by the light beam. This is shown in the following figure.

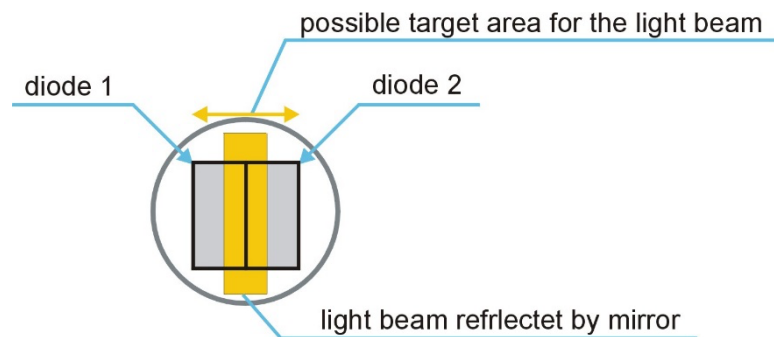

16.5 CHECKING SUM- AND DIFFERENCE VOLTAGES

This chapter describes the check of the sum and difference voltages. These voltages result from different light intensities reaching the sample side and the reference side of the light sensor. To perform the check follow the steps listed below:

- Make sure the instrument is switched on and both chambers of the flow cell are filled with distilled water (without bubbles). In this case the optical balance should be $0 \pm 20,0 \%$. To ensure a stable temperature the instrument should be switched on for several hours before performing this test.
- Press the **PURGE** button. Make sure the purge mode is activated, the red purge LED should light up.
- Use a disposable syringe to press approx. 5 mL distilled water through the flow cell
- The display will show the current detector signal. If no signal is displayed please check chapter **XXX**.
- Activate the service mode of the RI2012 by pressing the buttons **ArrowLeft** (◀) and **ArrowRight** (▶) at the same time for approx. three seconds. The display will change to the following

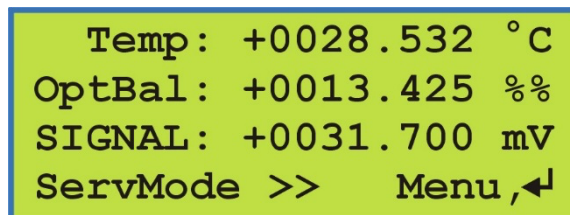

The image shows a screenshot of the RI2012 instrument's display in service mode. The display is green with black text. It shows four lines of data: 'Temp: +0028.532 °C', 'OptBal: +0013.425 %%', 'SIGNAL: +0031.700 mV', and 'ServMode >> Menu, ⏪'. The text is centered and the background is a solid green color.

- Press the **MENU** button until the status line in the display changes to ViewFine. Now press the **ENTER** button. The display will show four values.

```
Check Source Unit ←
-0010 5030 2510 2520
SIGNAL: +0031.700 mV
ServMode      ViewFine
```

To find out which value is displayed in which column press the **ENTER** button.
The display will change to the following view:

```
Check Source Unit ←
  Diff Summ Smpl Rfrn
SIGNAL: +0031.700 mV
ServMode      ViewFine
```

To go back to the former view press the **ENTER** button again.

- Diff** represents the difference voltage (in mV) and corresponds to the difference of intensity reaching the sample side and the reference side of the light sensor.
- Summ** represents the sum voltage (in mV) and corresponds to the light intensity reaching both sides of the light sensor.
- Smpl** represents the sample voltage which corresponds to the light intensity reaching the sample side of the light sensor.
- Rfrn** represents the reference voltage which corresponds to the light intensity reaching the reference side of the light sensor.

The voltages are calculated according to the following formulas

$$\text{Summ} = \text{Smpl} + \text{Rfrn}$$

$$\text{Diff} = \text{Smpl} - \text{Rfrn}$$

- Use a multimeter to check the lamp voltage at the test point on the circuit board. In both cases the lamp voltage should be set 3.7 ± 0.5 V. You can find a schematic view of the main circuit board with the marked positions of the test points at the end of manual.
- If the sum voltage is only a few millivolts the light bulb does not work. Check the power cables of the light source to make sure that they are connected properly. If needed check the light source (see chapter 16.4).

■ NOTE

- Both chambers of the flow cell are filled with the same solvent (without bubbles). In this case the optical balance should be in a range of $0 \pm 20,0$ %.
- The sum voltage should be in the region of 5000 ± 25 mV. If this is not the case adjust the lamp voltage by turning the potentiometer R19 until the sum voltage is in the region of 5000 ± 25 mV.
- Due to the adjustment of the light intensity it is necessary to check the lamp voltage again. If this voltage is not in the region von 3.7 ± 0.5 V the light source has to be re-adjusted.
- The optical system is adjusted properly if the sum voltage is 5000 ± 500 mV and the lamp voltage 3.7 ± 0.5 V.

16.6 CHECK AND REPLACEMENT OF THE VALVE

If the valve which is used to switch the path of the mobile phase in the normal measuring mode and purge mode needs to be replaced follow the following steps:

- Switch of the RI2012 refractive index detector and unplug the mains cable

■ **NOTE**

To prevent electrical shock make sure that the power cable is disconnected before opening the housing of the instrument.

- Remove the stainless steel capillaries from the valve body.

■ **NOTE**

Remind the position of the capillaries for proper re-connection.

- Loosen the control cable of the valve at the main circuit board.
- Loosen the two screws holding the valve body.
- Remove the valve body and replace with the new one.
- Tighten the holding screws and reconnect the capillaries in the correct positions.
- Connect the signal cable to the contact labelled "Valve" on the main circuit board.
- Start your chromatography pump to flush mobile phase through your RI2012 detector.
- Check the capillary connections for any leakage.
- Close the instrument's housing.

16.7 CHECKING AND CLEANING THE FLOW CELL

In some cases it might be necessary to clean the flow cell inside the RI2012 refractive index detector. You should try to wash away possible contaminations by purging both chambers of the flow cell with fresh mobile phase for a longer time.

If you are not sure if the problems are caused by a contaminated flow cell or caused by other problem contact the technical service of your local distributor or SRI Instruments Europe GmbH directly.

Possible reasons to open the optical bench for checking the flow cell:

- Drop of the sum voltage below 4500 mV. Make sure that your sample chambers are washed and filled with distilled water (without bubbles) before checking the sum voltage.
- Noisy baseline (may be caused by small particles in the flow cell)
- Constant drift of the baseline

To check the flow cell inside your detector follow the steps listed below:

- Switch off the instrument and unplug the power cable. Open the detector's housing after loosening the screws.

NOTE

When performing service work inside the instrument's housing make sure that the power cable is disconnected.

- Open the outer housing of the optical bench after loosening the screws
- Remove the heat insulation on top of the optical bench
- Open the inner (black) housing after loosening the screws
- Loosen the two hex-screws holding the slit aperture 2 and remove the aperture carefully

- Use a flash light to check the flow cell for contaminants or damages. Make sure that no bubbles are inside the flow cell.
- If there are contaminants in the flow cell purge it with a suitable solvent. If you are working with aqueous systems distilled water is convenient. If you use organic substances try solvents like acetone, tetrahydrofurane or chloroform. After purging the cell with solvent to clean for a longer time you should purge it with you mobile phase and check again if the contaminants is removed.

■ NOTE

In the case of dangerous solvents make sure that they are disposed correctly.

■ NOTE

In case of aqueous solvents it is possible that algae grow inside your chromatographic system. For that reason it is not recommended to store the detector for a longer time with aqueous solvents inside. For long time storage it is recommended to purge the flow cell with ethanol followed by air.

If possible we recommend the addition of a small amount of organic solvent (such as isopropanol or methanol) to your mobile phase to prevent algae growth.

If it is not possible to remove the contaminant from your flow cell it might be necessary to replace it with a new flow cell. Please contact your local distributor or SRI Instruments Europe GmbH directly for assistance.

If the flow cell is cleaned set the slit aperture back in its position and fix it.

Put the lid on the inner housing and tighten the screws.

Place the heat insulation back on top of the inner housing.

Close the outer housing and tighten the screws.

Perform a measurement to check if the problem is solved now. If you still have problems using your RI2012 refractive index detector please contact you local distributor or SRI Instruments Europe GmbH directly for assistance.

16.8 THE HEATING CIRCUIT OF THE RI2012

In the following chapter the complete specification of the RI2012 heating circuit is put together.

- In the normal measuring mode (NormMode) the temperature is displayed with one digit (e. g. 27.1 °C). If you want more detailed information you can switch to the service mode (ServMode) where the temperature is displayed with three digits (e.g. 27.094 °C).
- The temperature sensor will be detected automatically when the instrument is switched on.
- If the heating is switched off the optical bench is operated at a temperature of about 6 °C above ambient temperature due to heat irradiated of electronic compounds.
- In the interval from 35 °C up to 55 °C the temperature can be selected in 1 °C steps. The temperature difference of 6 °C has to be considered. If the heating is activated a asterisk (*) is shown in the upper left corner of the display.
- The heat cartridge used in the RI2012 refractive index detector has an internal resistance of 750Ω.
- The temperature sensor is controlled by the micro controller. Heating is deactivated and cannot be activated for one of the following reasons:
 - a) The temperature sensor does not work or is not connected to the main circuit board. In this case the error message “noTS” will be displayed.
 - b) The current temperature of the optical bench is below 9 °C or beyond 65 °C. In this case the error message “!” will show up and an acoustic signal occurs.
 - c) If the heating is not switched off properly by the firmware a thermal fuse will switch off the heating at a temperature of 72°C.

17 VOLTAGE TEST POINTS

The following list contains different test points on the main circuit board of the RI2012 refractive index detector.

All voltages listed below are measured in relation to Ground GND or AGND. Both are connected to the instrument's housing through the holding screws on the circuit board. Check the serial number of your instrument (see chapter 15.1) to locate the test points on the board. The figure on page **Error! Bookmark not defined.** shows the board used in instruments of the 0312xxx series. The figure on page **Error! Bookmark not defined.** shows the board used in instruments of the 0401xxx series.

GND	digital ground
AGND	analog ground

Uncontrolled voltages

Ud*	10.8 V	for RI2012 with serial number up to SN 0212220
	11.3 V	for RI2012 with serial number from SN 0212221

Stabilized voltages

Vcc	controlled voltage for digital circuits
U _{Lmp}	controlled lamp voltage
U _{ref} or TP14	reference voltage for the A/D-converter

Test point	Voltage	Adjustment
Vcc	5.0 V	-
U _{Lmp}	2.5 to 5.1 V	Potentiometer R19
+12 V	+12 V	-
-12 V	-12 V	-
+5 V	+5 V	-
-5 V	-5 V	-
U _{ref} or TP14	2.5 V	-

Position of test points see next page

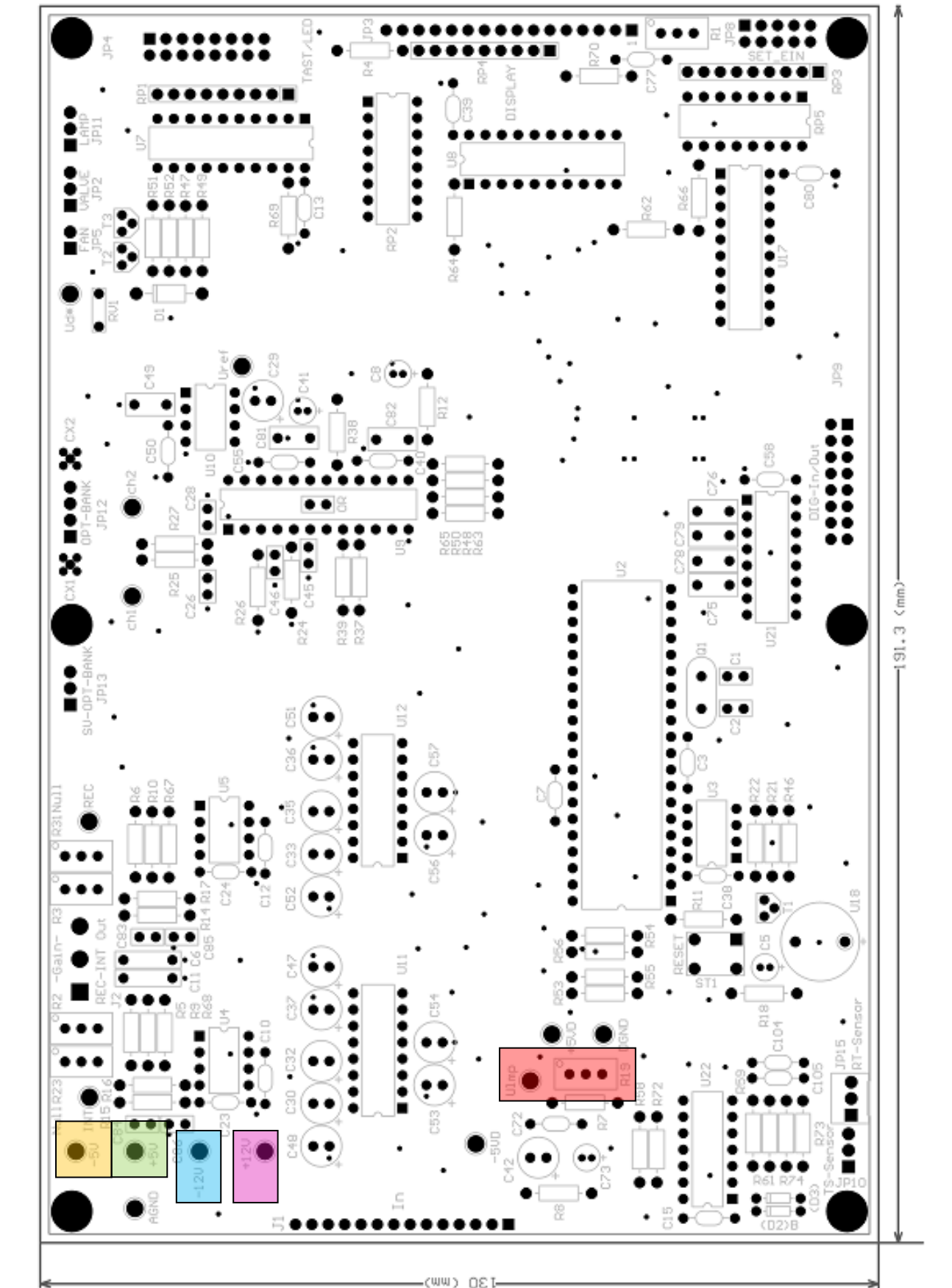

Signal voltages

The voltages you find at this test point should correspond to the voltages shown in the detector's display in ViewFine mode.

Test point	Voltage
ch1	corresponding to Smpl voltage of the optical bench
ch2	corresponding to Rfrn voltage of the optical bench
INT	voltage of the analog integrator output
REC	voltage of the analog recorder output

18 SPARE PARTS

Article No.	Description
RI2012-024	Set of flow cell seals (4 pcs.) for RI2012 (Necessary for all types of flow cells)
RI2012-001	Flow cell (analytical version) RI2012
RI2012-003	Flow cell holder (analytical version) RI2012
RI2012-030	Flow cell (micro version) RI2012
RI2012-005	Flow cell holder (micro version) RI2012
RI2012-031	Flow cell (preparativ version) RI2012
RI2012-004	Flow cell holder (preparativ version) RI2012
RI2012-006	Purge valve Typ ASCO - RI2012
RI2012-012	Light source RI2012
RI2012-023	Fan RI2012
RI2012-D03	Teflontube RI - outlet
90-ZBU1C	Inlet port RI2012, analytical and micro , 0,25mm ID
90-ZBU1	Inlet port RI2012, preparativ, 0,75mm ID
90-ZBU1	Outlet port RI2012, analytical, 0,75mm ID

Spare parts you can order from your local distributor or SRI Instruments Europe GmbH directly.

DECLARATION OF CONFORMITY

Konformitätserklärung Declaration of Conformity Déclaration de Conformité

Wir
We
Nous

SRI Instruments Europe GmbH

Anschrift
Address
Address

Menzenberger Str. 93
D-53604 Bad Honnef
Germany

erklären in alleiniger Verantwortung, dass das Produkt:
declare under our sole responsibility, that the product:
déclarons sous notre seule responsabilité, que le produit:

Bezeichnung
Name
Nom

Brechungsindexdetector
Refractive Index Detector

Typ, Modell, Artikel-Nr.,
Type, Model, Article No.,
Type, Modèle, Mo. d'Article,

RI2012

Verwendete Werkstoffe:
Applied Materials:
Materiaux utilisés:

mit den Anforderungen der Normen und Richtlinien
fulfills the requirements of the standard and regulations of the Directive
satisfait aux exigences des normes et directives

73/23/EWG **Niederspannungsrichtlinie/Low Voltage Regulation**
DIN EN 61010 Sicherheitsbestimmungen für elektrische Mess-, Steuer-, Regel- und Laborgeräte

89/336/EWG **Elektromagnetische Verträglichkeit EMV**
DIN EN 50081 *Fachgrundnorm Störaussendung*
EN 55022 Messung der Funkstörspannung von 150 kHz bis 30 MHz
EN 55022 Messung der Funkstörfeldstärke von 30 MHz bis 1 GHz

DIN EN 50082 *Fachgrundnorm Störfestigkeit*
IEC 1000-4-2 Prüfung der Störfestigkeit gegen Entladung statischer Elektrizität
ENV 50140 Prüfung der Störfestigkeit gegen hochfrequente Einstrahlung
IEC 1000-4-4 Prüfung der Störfestigkeit gegen schnelle transiente Impulse
ENV 50142 Prüfung der Störfestigkeit gegen Stoßspannungen
ENV 50141 Prüfung der Störfestigkeit gegen Hochfrequente Einkopplung
IEC1000-4-11 Prüfung der Störfestigkeit gegen Netzunterbruch

und den angezogenen Prüfberichten übereinstimmt und damit den Bestimmungen entspricht.
and the taken test reports and therefore corresponds to the regulations of the Directive.
et les rapports d'essais notifiés et, ainsi, correspond au règlement de la Directive.

Bad Honnef, 01. October, 1999

Karl-Heinz Schambeck

Ort und Datum der Ausstellung
Place and Date of Issua
Lieu et date d'établissement

Name und Unterschrift des Befugten
Name and Signature of authorized person
Nom et signature de la personne autorisée